

APPROVED
Version 40
April 20, 2021

Communication Signal for Rapid Shutdown SunSpec Interoperability Specification



Abstract

This document defines a multi-vendor, multi-device (e.g. inverter, module, string combiner) communication interoperability specification to support NEC 2014, NEC 2017 and UL 1741 module-level rapid shutdown requirements. The intended audience for this document includes hardware and software designers as well as implementers of communication systems.

License Agreement and Copyright Notice

THIS DOCUMENT AND THE INFORMATION CONTAINED HEREIN IS PROVIDED ON AN "AS IS" BASIS AND THE SUNSPEC ALLIANCE DISCLAIMS ALL WARRANTIES, EXPRESS OR IMPLIED, INCLUDING BUT NOT LIMITED TO ANY WARRANTY THAT THE USE OF THE INFORMATION HEREIN WILL NOT INFRINGE ANY OWNERSHIP RIGHTS OR ANY IMPLIED WARRANTIES OF MERCHANTABILITY OR FITNESS FOR A PARTICULAR PURPOSE.

THIS DOCUMENT MAY BE USED, COPIED, AND FURNISHED TO OTHERS, WITHOUT RESTRICTIONS OF ANY KIND, PROVIDED THAT THIS DOCUMENT ITSELF MAY NOT BE MODIFIED IN ANYWAY, EXCEPT AS NEEDED BY THE SUNSPEC TECHNICAL COMMITTEE AND AS GOVERNED BY THE SUNSPEC IPR POLICY. THE COMPLETE POLICY OF THE SUNSPEC ALLIANCE CAN BE FOUND AT WWW.SUNSPEC.ORG.

Attribution

This specification was developed by the SunSpec Alliance Communication Signal for Rapid Shutdown Workgroup. This workgroup includes the following individuals and companies:

Sauro Macerini, Giovanni Manchia, Ronnie Pettersson, Robert White, Mirco Mirra, Enrico Pietrantozzi (ABB); Andrew Misenheimer (Alevo Inc.); Devin Cao, Daniel Richardson (Canadian Solar); Anton Fischer (Celestica); Peter Chung, Nick Lee (Delta Products Corp.); John Berdner (Enphase); Martin Beran, Christian Fasthuber, Brian Lydic, Christoph Wolf (Fronius); Bernie Grant, Terence Parker (Ginlong-Solis); Ben Castillo, Bill Reaugh (KACO new energy); Chetan Chaudhari, Seth Kahn, Charles Razzell, Ryan Ricchiuti (Maxim Integrated); Thierry Arnaud, Ali Julazadeh (Mersen); Ryan Stankevitz (Midnite Solar); Ozgur Aksoy (Monitek LLC); Erica Martin (Omron Electronic Components LLC); Andrew Ahmad, Anand Janaswamy (OneRoof Energy); Brian Faley, Philip Undercuffler, Mara White (OutBack Power); Lotte Ehlers, Wolfgang Hoëft (Phoenix Contact); Larry Sherwood (Sherwood Associates); Markus Hopf, Hannes Knopf, Michael Viotto (SMA Solar Technology); Alex Mayer, Sandeep Narla, Jake West (SolarCity); Steve Robbins (Sunfield Semiconductor); Jonathan Ehlmann, Kelly Mekechuk (SunPower); Tom Tansy (SunSpec Alliance); Amneh Akour, Dick Hester, Il Han Kim, Nat Natarajan, Tim Pauletti (Texas Instruments); Gal Bauer, Vered Sharon, Bijay Shrestha, Danny Eizips (Tigo Energy); Chris Flueckiger, Tim Zgonena (UL); Ward Bower (Ward Bower Innovations); Emily Hwang, Aegir Jonsson (Yaskawa Solectria Solar); Ralf Schulze (Yingli).

Contact Information

SunSpec Alliance

4040 Moorpark Avenue, Suite 110

San Jose, CA 95117

info@sunspec.org

Revision History

Revision	Date	Reason
1	09-02-2015	First Draft in SunSpec Template
2	09-09-2015	General requirements revised per discussion at 9/9/15 Work Group meeting.
3	10-7-2015	Section 3.1 Power Line Communication Requirements added,
4	10-15-2015	Changes added from 10/14/15 meeting
5	10-28-2015	Revision to Section 3.1.2, notes from 10/28/15 meeting
6	11-4-2015	Add Wireless Protocol
10	11-25-15	Add all changes discussed at meetings through November 25. Add revised Wireless Section 6
11	12-16-15	Add revised Wireless Proposal.
12	1-18-16	Changes defined frequencies, add Section 5.4.2 on Continuous Phase, make editorial changes throughout the document.
13	2-26-16	Incorporates edited copy throughout document and removed the wireless section to a separate document.
14	3-2-16	Incorporates edits from March 2, 2016 meeting
15	3-9-16	Incorporates edits from March 9, 2016 meeting
16	3-16-16	Incorporates edits from March 16, 2016 meeting
17	4-11-16	Incorporates edits from March 31, 2016 meeting and add Definition table and description of optional requirements.
18	5-18-16	Incorporated edits from May 18, 2016 meeting.
19	5-27-16	Incorporates changes inferred from the output of the Amplitude/EMC subgroup chaired by Michael Viotto
20	6-1-2016	Updated Table 1: Mode Transition Parameters to incorporate input.

21	6-28-2016	Updated formatting and layout, removed test plan outline.
22	8-30-2016	<ul style="list-style-type: none"> (1) Updates to incorporate 3-on, 13-off duty cycle for AFD. (2) Included ± 100ppm frequency tolerance allowance at the transmitter. (3) Required that receivers must tolerate ± 100ppm frequency tolerance at the transmitter (4) Improved sensitivity requirement and reduced minimum receiver impedance per Amplitude Subgroup recommendations. (5) Stipulated MSB-first bit ordering in Table 5 footnote. (6) Defined an optional code to mean accelerated shutdown. Neither Transmitters nor Receivers are required to implement this.
23	9-07-2016	Replace Barker-13 word with Barker-11 word. Keep timing approximately constant by increasing number Zero codewords to 16. Resultant duty cycle is 3-on, 16-off.
24	9-16-2016	Adjust input impedance Z_{rx} after updated tolerance analysis.
25	9-21-2016	<ul style="list-style-type: none"> • Changed terminology of master/slave to transmitter/receiver • Added Figure 1 • Added Figure 5 • Added footnote 5 to Table 5 • Added Appendix D
26	10-3-16	<ul style="list-style-type: none"> • Added revised Figure 1 • Added changes from 9/28/16 meeting • Added revisions to Table 6
27	10-20-16	<ul style="list-style-type: none"> • Final copy editing
28	10-28-16	<ul style="list-style-type: none"> • Changes discussed at 10/26/16 Working Group meeting added
29	4-13-17	<ul style="list-style-type: none"> • Revise Footnote 5 to Table 6 • Table 6 – revise T_s
30	4-26-17	<ul style="list-style-type: none"> • Change to timing requirements in Section 4.4

		<ul style="list-style-type: none"> • Values changes in Figure 5 and Table 5 • Table 4 revised to agree with Table 4.
32	6-7-17	<ul style="list-style-type: none"> • Cleaned up numbering of requirements • Edits to Section 4.3 • Edits to Table 1 and footnotes to Table 1 • Revised Requirement 5.2.6 • Revised Table 6 for Proprietary Use and Reserved signals; added footnotes 2-4 • Edited total of Appendix C • Corrected values in Appendix D
33	06-14-17	<ul style="list-style-type: none"> • Editorial revisions to Requirements 5.1.1 and 5.2.4 and Footnote 2 for Table 6.
34	08-21-17	<ul style="list-style-type: none"> • Made formatting changes • Updated status to APPROVED
35	06-25-19	<ul style="list-style-type: none"> • Incorporated changes to sections 4.2 and 4.3 to address applications of the receiver in devices that are not PV modules • Referenced to UL 3741 in Appendix A • Set document status to TEST
36	08-27-2019	<ul style="list-style-type: none"> • Accepted changes from v35 • Set document status to APPROVED
37-38	03-02-2021	<ul style="list-style-type: none"> • Changes introduced to support multi-module implementations, coexistence with arc fault detection on the power line, and clarify existing requirements
39	03-09-2021	<ul style="list-style-type: none"> • Incorporated formatting changes • Set status to TEST • Published PDF version for review and comment by all SunSpec Alliance members
40	04-20-2021	<ul style="list-style-type: none"> • Set status to APPROVED

About the SunSpec Alliance

The SunSpec Alliance is a trade alliance of developers, manufacturers, operators and service providers, pursuing open information standards for the Distributed Energy industry. SunSpec Alliance standards address operational aspects of PV, storage and Distributed Energy power plants on the smart grid—including residential, commercial, and utility-scale systems— thus reducing cost, promoting innovation, and accelerating industry growth.

Global leaders from Asia, Europe, and North America are members of the SunSpec Alliance. Membership is open to corporations, non-profits, and individuals. For more information about the SunSpec Alliance, or to download SunSpec specifications at no charge, please visit www.sunspec.org.

About the SunSpec Specification Process

SunSpec Alliance specifications are developed by SunSpec member companies seeking to establish industry standards for mutual benefit. Any SunSpec Alliance member can propose a technical work item. Given sufficient interest and time to participate, and barring significant objections, a workgroup is formed. Workgroups meet regularly to advance the agenda of the team.

The output of a workgroup is a SunSpec interoperability specification. SunSpec interoperability specifications are considered to be normative, meaning that there is a matter of conformance required to support interoperability. The revision and associated process of managing these documents is tightly controlled. Other SunSpec documents are informative, and provide recommendations regarding best practices, but are not a matter of conformance. Informative documents can be revised more freely and frequently to improve the quality and quantity of information provided.

SunSpec interoperability specifications follow this lifecycle pattern of DRAFT, TEST, APPROVED and SUPERSEDED.

For more information or to download a SunSpec Alliance specification, go to <http://sunspec.org/about-sunspec-specifications/>.

Contents

License Agreement and Copyright Notice.....	2
Attribution	2
Contact Information	2
About the SunSpec Alliance	6
About the SunSpec Specification Process	6
Definitions.....	9
1 Overview	10
2 Specification Objectives.....	10
3 General Requirements	10
3.1 System Configuration	11
3.2 Operational Considerations.....	13
3.3 Safety Considerations.....	13
4 Modes of Operation	13
4.1 Active Mode.....	13
4.2 Shutdown Mode.....	14
4.3 Standby Signal/Standby Power.....	14
4.4 Mode Transitions.....	14
4.5 Mode Transition Parameters.....	15
5 Power Line Communication (PLC) Requirements	16
5.1 Transmitter Requirements	16
5.2 Receiver Requirements	19
5.3 PLC Protocol Requirements	21
6 Test Plan Specification	24
7 Appendix A: References	25
8 Appendix B: Spread Frequency Shift Keying (S-FSK) Principle.....	26
9 Appendix C: Standby Signal	27
10 Appendix D: PV System Configuration Limits for The Provided Power Line Communication Values	27
11 Appendix E: Multi-module RSD	28

Tables

Table 1: Mode Transition Parameters 15

Table 2: Out-of-Band Spectral Mask Parameters 18

Table 3: In-Band Spectral Mask Parameters 18

Table 4: Rejection Ratio Values 20

Table 5: In-Band Rejection Values 21

Table 6: Power Line Communication Values 23

Figures

Figure 1: SunSpec Rapid Shutdown System 11

Figure 2: Out-of-Band Spectral Mask Graphic 18

Figure 3: In-Band Spectral Mask Graphic 19

Figure 4: Rejection Ratio Graph 20

Figure 5: In-Band Rejection Graphic 21

Figure 6: FSK on Frequency Domain 26

Definitions

Term	Meaning
Components	Equipment intended to be used in a PV Rapid Shutdown System to initiate, disconnect, isolate or attenuate the controlled conductors of a PV system. (UL 1741, Section 2.49D). UL 1741 refers to components as PV Rapid Shutdown Equipment (PVRSE).
Communication Protocol	Formal descriptions of digital message formats and rules.
Initiation Device	A manual or automatic switching device, input port or signal that will result in the activation of the Rapid Shutdown System function(s). An initiation device is intended to meet the function of the initiation methods mentioned in Section 690.12 of the National Electrical Code (UL 1741, Section 2.49B). The Initiation Device is the same as the Initiator.
PV Power Source	A dc array or aggregate of arrays that generates dc power. (see NEC, Section 690.2)
Receiver	The equipment that is responsible for accepting the communication signal sent by a Transmitter and is capable of initiating a state change of PV power source components based on the signal received. (see Section 3.1 of this document)
System	System made up of components intended to disconnect, isolate or attenuate the controlled conductors of a PV system. (see UL 1741, Section 2.49E)
Rapid Shutdown System	Collection of Components and Communication Protocols that are used to fulfill rapid shutdown requirements as defined by NEC 2014 or NEC 2017. Components of a rapid shutdown communication system are Initiator(s), Transmitter(s), and Receiver(s).
PV Rapid Shutdown Equipment (PVRSE)	Equipment intended to be used in a PVRSS to initiate, disconnect, isolate or attenuate the controlled conductors of a PV system.
PV Rapid Shutdown System (PVRSS)	System consisting of PVRSE intended to initiate, in addition to disconnect, isolate or attenuate the controlled conductors of a PV system.
Rapid Shutdown Device (RSD)	PVRSE intended to be used in a PVRSS to disconnect, isolate or attenuate the controlled conductors of a PV system.
Transmitter	The equipment that is responsible for sending a communication signal that reflects the current state of the Initiation Device. (see Section 3.1 of this document)

1 Overview

The National Electrical Code (NEC) applies to the construction of PV systems installed on buildings and does not apply to ground-mount PV systems. The 2014 version of the NEC (NEC 2014) includes a requirement for rapid shutdown of controlled conductors outside the PV array boundary. The 2017 version of the NEC (NEC 2017) includes a requirement for module-level shutdown. The module-level shutdown requirement became effective January 1, 2019 rather than January 1, 2017 for the rest of the code. The 2020 version (NEC 2020) became effective in 2020 and carries forward NEC 2017 requirements.

To meet the requirements of the 2017 NEC and UL 1741, it is advantageous for modules, inverters, charge controllers, and other equipment to communicate with each other. Furthermore, it is desirable to have a single communication protocol to provide interoperability between the different components from different manufacturers that are required to participate in a Rapid Shutdown System. This specification describes a Rapid Shutdown System communication protocol.

It is possible to achieve NEC compliance without a Rapid Shutdown System communication protocol. This specification does not apply in that case.

2 Specification Objectives

The objectives of this specification are:

- Identify the communication requirements specified or implied by NEC 2014, NEC 2017, NEC 2020 and UL 1741 that pertain to module-level rapid shutdown. For multi-module shutdown (e.g. two modules or string level), requirements are also defined throughout the document where relevant and in Appendix E: Multi-module RSD.
- Describe a communication framework that is open, flexible, scalable, and available royalty-free to manufacturers of power electronics, PV modules, inverters, and PV balance-of-system components that addresses module-level rapid shutdown requirements.
- Define parameters and operating ranges associated the communication framework to support module-level rapid shutdown such that disparate components can be evaluated for conformance to this specification and multi-vendor interoperability can be achieved.

This document is offered at no cost from SunSpec.org and is part of a library of royalty-free SunSpec Alliance interoperability specifications.

3 General Requirements

These general requirements apply to PV system components and communication networks supporting the Rapid Shutdown System communication capabilities defined in relevant NEC and UL standards.

This SunSpec Communication Signal for Rapid Shutdown Specification defines how to propagate the operational state of the entire PV system to the individual power production components comprising the PV system. The document also describes requirements and constraints associated with power line communication networks that are used to support this application.

3.1 System Configuration

A Rapid Shutdown System is a collection of Components and Communication Protocols that are used to fulfill rapid shutdown requirements as defined by NEC 2014 or NEC 2017. Components of a rapid shutdown communication system are Initiator(s), Transmitter(s), and Receiver(s).

The SunSpec Communication Signal for Rapid Shutdown Specification is designed to support rapid shutdown requirements of any PV system governed by NEC 2014, NEC 2017, NEC 2020 or applicable UL standard(s), irrespective of system configuration. Issues that commonly affect application protocol performance, such as cross-talk from other protocols, noise, and line impedance, must be accounted for.

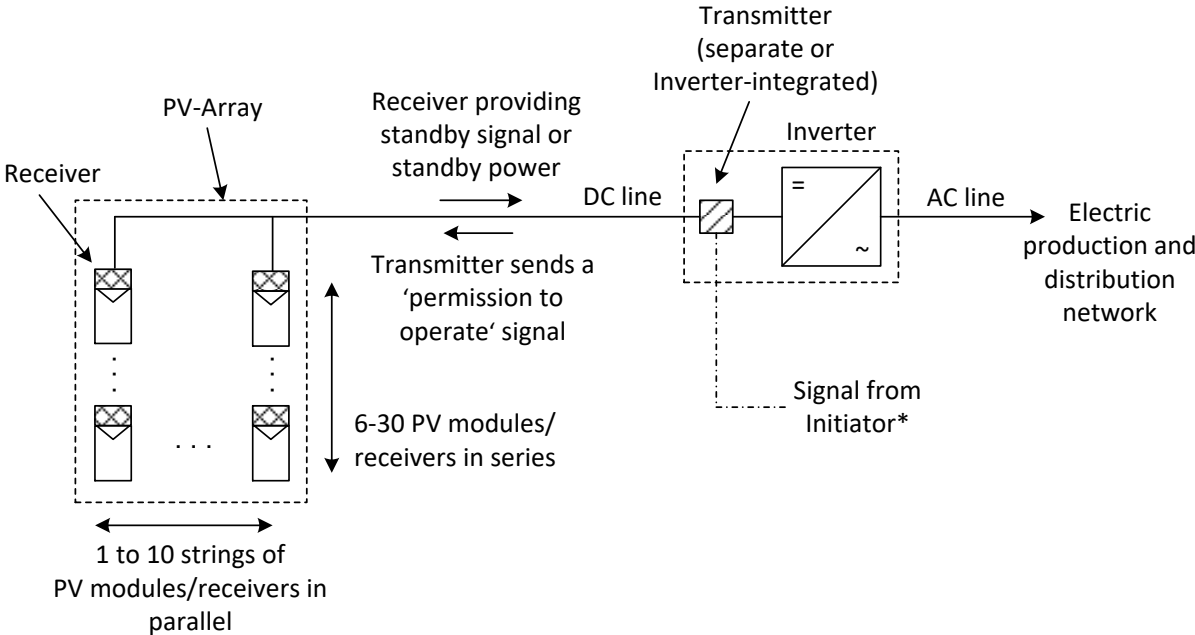

*All initiators defined in NEC 2017, art. 690.12 (C) 'Initiation Device' are permitted

Figure 1: SunSpec Rapid Shutdown System

Initiator

An Initiator is the equipment that is responsible for initiating the rapid shutdown mechanism in the System.

The term Initiator, in this context, is defined in the 2017 NEC.

3.1.1 Requirement: A System must have one or more Initiator(s).

Transmitter

A Transmitter is the equipment that is responsible for sending a communication signal that reflects the current state of the Initiator. The portion of the PV system controlled by a single Transmitter is referred to as a Sub-system. The minimum and maximum size of a Sub-system supported by a single Transmitter is manufacturer-dependent and must be specified by the manufacturer.

3.1.2 Requirement: A System must have at least one Transmitter.

3.1.3 Requirement: A Sub-system must have only one Transmitter.

3.1.4 Requirement: A Transmitter must comply with the minimum output voltage and minimum output source impedance specified in Table 1: Mode Transition Parameters.

Receiver

A Receiver is the equipment that is responsible for accepting the communication signal sent by a Transmitter and is capable of initiating a state change of PV power source components based on the signal received.

3.1.5 Requirement: A Sub-system must have at least one Receiver.

Transmitter/Receiver Interactions

Transmitter/Receiver interactions are at the heart of Communication Signal for Rapid Shutdown operation. By optimizing for efficiency and simplicity, low-cost and reliable system solutions are possible.

3.1.6 Requirement: A Transmitter must transmit a permission to operate signal to Receivers when the Initiator indicates rapid shutdown is not active.

3.1.7 Requirement: A Transmitter must stop transmitting a permission to operate signal to Receivers when the Initiator indicates rapid shutdown is active.

3.1.8 Requirement: A Receiver must be able to receive a permission to operate signal and initiate the ability of the associated power-producing equipment to produce power.

3.1.9 Requirement: A Receiver must detect the absence of a permission to operate signal and initiate the shutdown of power production by associated power producing equipment.

Informative Note: A receiver does not have to perform the shutdown if it receives more than one permission to operate signal simultaneously.

3.2 Operational Considerations

Operational simplicity is a key goal of the Communication Signal for Rapid Shutdown Specification. Complexity or unnecessary human interaction is to be avoided if possible.

3.2.1 Requirement: Rapid Shutdown Systems must provide a mechanism to bring the PV system(s) back online after a rapid shutdown event.

Local regulations may add requirements for start-up activation.

3.3 Safety Considerations

Mandatory features of the Communication Signal for Rapid Shutdown Specification represent minimum functionality required to achieve NEC 2014, NEC 2017, or NEC 2020 safety standards.

3.3.1 Requirement: Communication Signal for Rapid Shutdown Systems must support shut down in a manner that meets the function safety requirements of UL 1741.

3.3.2 Requirement: Communication Signal for Rapid Shutdown System must energize the PV system only when Initiator mechanism is set to “permission to operate” position.

3.3.3 Requirement: Communication Signal for Rapid Shutdown Systems must conform to applicable UL standard(s).

4 Modes of Operation

Two modes of operation are defined for a Rapid Shutdown System: Active Mode and Shutdown Mode. Active Mode is characterized by the typical state of a PV system, generating power unimpeded by the Rapid Shutdown System. For this condition to persist, the Initiator must be set to the “on” state. If the Initiator is set to “off” state, the respective Transmitter (including all Sub-systems) must enter the Shutdown Mode. Transitioning from Active Mode to Shutdown Mode must comply with overall timing constraints as set forth in NEC 2017. There are no timing constraints when transitioning from Shutdown Mode to Active Mode.

4.1 Active Mode

No specifications or restrictions are placed on PV generators during the Active (power producing) Mode. The Rapid Shutdown System must continuously monitor the Initiator for a change in operating state.

4.2 Shutdown Mode

NEC 2017 and NEC 2020 specifications require the illuminated PV system to be in a controlled state when in the Shutdown Mode.

4.2.1 Requirement: The output power of the PV system in Shutdown Mode must be controlled in accordance with NEC 2017.

4.3 Standby Signal/Standby Power

When in shutdown mode, the receiver shall provide a standby signal to indicate the presence of irradiance. The standby signal shall be a non-zero output voltage and current within the range allowed by NEC Article 690.12 (B)(2). Please see Appendix C: Standby for additional information about the advantages of this approach.

Furthermore, it is possible for Receiver(s) to provide enough standby power to supply both the standby signal and the “permission to operate” circuitry (e.g. the Transmitter or signal generator and a circuit which measures and signals the Shutdown operation) from the illuminated PV generator. This prevents a deadlock with purely PV powered systems. With this feature no AC supply is needed to power up the system.

4.3.1 Requirement: The minimum current available in the shutdown state must be sufficient to guarantee operation of equipment monitoring the state of the modules as specified in Table 1: Mode Transition Parameters.

4.3.2 Requirement: When in the Shutdown state, each PV generator must provide output voltage V_{OFF} , with minimum current I_{OFF} as defined in Table 1: Mode Transition Parameters.

4.3.3 Option (Standby Power): When in the Shutdown state, each PV generator must provide output voltage V_{OFF} , with minimum current I_{OFFHI} .

When offering power to the Transmitter is desirable, higher current capability is required. Standby Power (4.3.3) is an option and not a requirement but may be implemented and validated for conformance to this specification.

4.4 Mode Transitions

NEC 2014, NEC 2017, and NEC 2020 allow for 30 seconds from the initiation event until the system must be fully settled in the de-energized Shutdown Mode. In order to facilitate interoperability, it is important that the total time to de-energize is equitably allocated to the constituent steps of the de-energization process.

A typical de-energization process (mode transition) can be considered as the following sequence of events.

TT1: Initiator signals Shutdown Mode to Transmitter

TT2: Transmitter ceases to send permission to operate signal to Receiver(s)

TT3: Receivers de-energize all PV Power Sources

TT4: Inverter stored charge is eliminated

The timing requirements for this sequence of events are indicated in Table 1: Mode Transition Parameters.

There is a single requirement placed on the system with respect to a mode transition from Shutdown Mode to Active Mode.

TR1: Time for Receivers to enable PV power generation after compliant KeepAlive signaling commences at the output of the Transmitter.

4.5 Mode Transition Parameters

The following values and parameter ranges are **Requirements** of the Mode Transition attributes of this specification.

Symbol	Mode Specification	Min.	Max.	Unit	Remark
V_{OFF}	PV Power Source voltage in Shutdown	0.6	NA	V	Accommodates % or fixed methods
I_{OFF}	Output current for V_{OFF} tolerance window	10	NA	mA	Requirement
I_{OFFHI}	Output current for V_{OFF} tolerance window for high power option	400	NA	mA	Option
TT1	Time for Initiator to relay to Transmitter	NA	2	s	
TT2	Time for Transmitter to stop permission to operate signal	NA	2	s	
TT3	Time for Receiver to de-energize PV Power Sources	NA	13	s	
TT4	Time for Inverter stored charge to be eliminated	NA	13	s	
TT5	Total time to complete TT1+TT2+TT3+TT4	NA	30	s	
TR1	Time for Receivers to enable PV power generation after compliant KeepAlive signaling commences at the output of the Transmitter.	NA	20	s	Under all expected operating conditions.

Table 1: Mode Transition Parameters

(V_{OFF})

According to NEC 2017 the generator voltage in shutdown mode shall not exceed 30 V. This requirement limits the maximum number of modules that can be connected in series in dependence on V_{OFF} . The smaller V_{OFF} , the more modules can be put into one string. In contrast, a higher V_{OFF} is more useful for installation and maintenance of the system. For example, with the maximum V_{OFF} of 1 V, strings with 30 modules are possible, allowing for a wide range of systems.

The maximum number of the modules in a string is defined by the PV module output voltage and the Maximum System voltage. The Max V_{OFF} times the maximum number of the modules in a string shall not exceed 30V.

In addition to choosing a fixed voltage for this parameter, the wide range allows a relative value which depends on the actual open circuit voltage of the switched off module. This gives information on the available PV voltage, which can help during installation and

operation. As an example for a typical 60 cell PV module the value for V_{OFF} can be chosen as 2% of the actual voltage of the PV module. This would result in a V_{OFF} of 0.8V at an actual 40 V open circuit voltage of the PV module. The manufacturer of the module should provide information about the implementation (fixed or relative) and the value of V_{OFF} in the product data sheet.

(I_{OFFHI})

According to NEC 2014 and UL 1741, the generator current in shutdown mode shall not exceed 8 A (240VA). This requirement limits the maximum number of strings that can be connected in parallel in dependence on this parameter. The smaller I_{OFFHI} , the more strings can be implemented in parallel. In contrast, a higher I_{OFFHI} is more useful for powering auxiliary circuitry to prevent the dead lock situation described in Section 4.3. For example, with a I_{OFFHI} of 0.8 A, PV generators with 10 strings in parallel are allowed. The choice of a larger I_{OFFHI} can be beneficial for the overall system (e.g. less requirement on the auxiliary circuit, better startup of the system at low generator voltage). The value for I_{OFFHI} can be chosen by the designer of the PV module and is dependent on the anticipated use of the PV module. A PV module which is targeted at off grid systems could have a higher I_{OFFHI} because the system start up on PV power only has a high value in this application which can justify the additional effort in the module integrated electronics with a higher I_{OFFHI} . The manufacturer of the module should give information about the value of I_{OFFHI} in the data sheet.

Total Time

The total time for shutdown is 30 seconds per the 2014 and 2017 NEC.

5 Power Line Communication (PLC) Requirements

A Transmitter communicates with all Receivers in the Sub-system over Power Line Communications. The Transmitter continuously transmits a “permission to operate” bit sequence to indicate PV Power Sources have permission to operate in the Active Mode. If the Transmitter ceases to transmit the permission to operate sequence then the Sub-system enters the Shutdown Mode. Other bit sequences are defined and reserved for future use.

5.1 Transmitter Requirements

The Transmitter broadcasts a permission to operate signal using a Spread Frequency Shift Keying (S-FSK) modulation. The Transmitter must provide the Receiver(s) with signals at satisfactory level for demodulation. It must develop sufficient power on a given load impedance and must have a well-defined output impedance.

- 5.1.1 Requirement: Transmitter(s) must continuously send a cyclical code sequence, which includes 'permission to operate' when an Initiator indicates rapid shutdown is not active, corresponding to the code sequences defined in Table 6.**
- 5.1.2 Requirement: Transmitter(s) must have an output impedance in the range specified for Z_{OUT} in the transmission frequency band F_M to F_S .**
- 5.1.3 Requirement: Transmitter(s) must provide an open circuit output voltage in the range specified for V_{TX} .**
- 5.1.4 Requirement: Transmitter(s) must transmit permission to operate signal using a mark and space tone frequency of F_M and F_S respectively.**
- 5.1.5 Requirement: Transmitter(s) must maintain the transmission of a mark or a space tone for T_S duration.**
- 5.1.6 Requirement: Transmitter(s) must transmit 'permission to operate' signals according to a fixed duty cycle defined by an integer number of consecutive transmitted code words followed by an integer number of zero-energy code words.**
- 5.1.7 Requirement: Transmitter(s) must maintain phase coherency when transitioning between mark and space tones.**
- 5.1.8 Requirement: Transmitter(s) must maintain SFSK tone frequencies (F_M and F_S) and effective bit rate (R_S) to within a ± 100 ppm tolerance when in operation inclusive of allowances for temperature and aging.**
- 5.1.9 Requirement: Transmitter(s) must ensure that the SFSK tone frequencies and the effective bit rate remain proportional to each other for variations within their permitted tolerances.**

Transmitter Out-of-Band Emission Requirements

The Transmitter(s) must not generate spurious out-of-band signals that could interfere with other communication systems or with PV system components like MPP tracker or AFCI.

5.1.10 Requirement: the Out-of-Band spurious frequency components must not exceed the levels defined in Table 2 and depicted in Figure 2.

Out-of-Band Spectral Mask								
				$F_M - 11.25$	$F_M - 11.25$	$\min(F_s + 11.25, 150)$	$\min(F_s + 11.25, 150)$	
F [kHz]	0	72	72	120	120	150	150	1000
P [dBm]	-60	-60	-40	-40	0	0	-40	-40

Table 2: Out-of-Band Spectral Mask Parameters

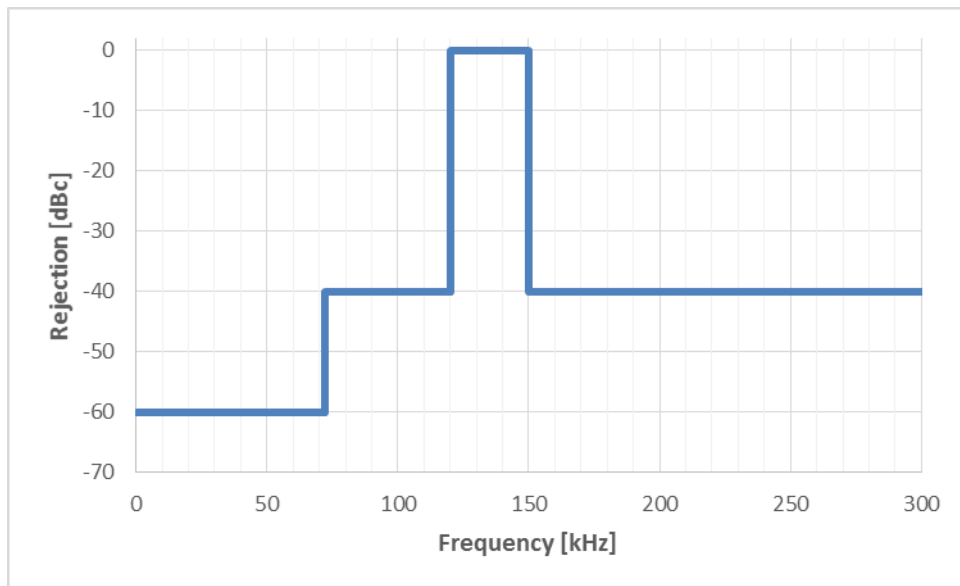

Figure 2: Out-of-Band Spectral Mask Graphic

Transmitter In-Band Emission Requirements

To ensure easy separation of the carriers in the demodulator, the in-band spectrum of the two FSK carriers must be limited.

5.1.11 Requirement: In-Band frequency components must not exceed the levels defined in Table 3 and depicted in Figure 3.

The frequency and amplitude values are relative to the actual frequency and power of each of the two FSK carriers.

In-Band Spectral Mask					
F-Fc [kHz]	$-50 < F \leq -9$	$-9 < F \leq -5$	$-5 < F \leq 5$	$5 < F \leq 9$	$9 < F \leq 50$
P [dBc]	-30	-20	0	-20	-30

Table 3: In-Band Spectral Mask Parameters

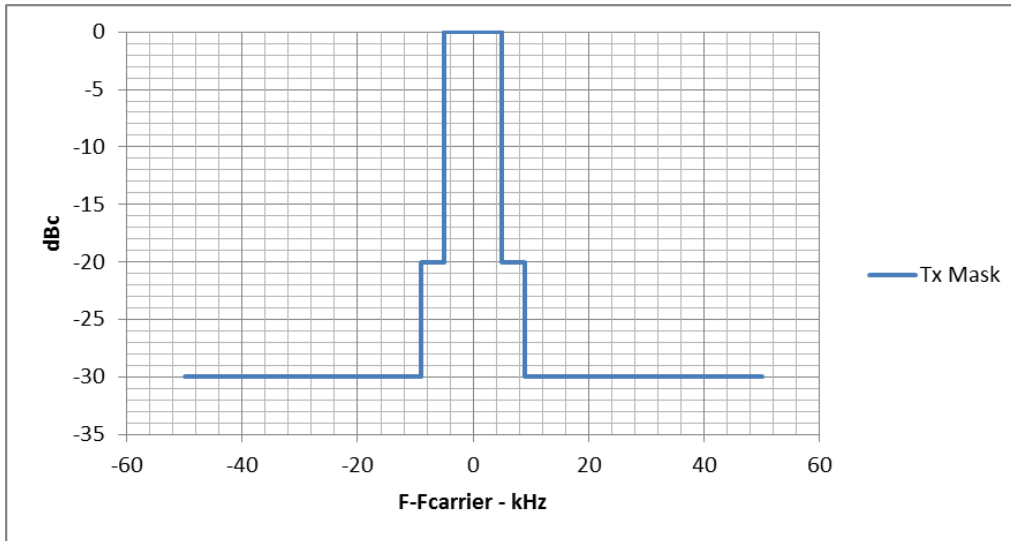

Figure 3: In-Band Spectral Mask Graphic

5.2 Receiver Requirements

The Receiver(s) must be able to handle a large range of input signal amplitude. Maximum amplitude is received with maximum TX power and minimum PV string attenuation, and conversely, minimum signal is received with minimum TX power and maximum PV string attenuation.

5.2.1 Requirement: Receiver(s) must decode the FSK signals at F_M and F_S as sent by the Transmitter.

5.2.2 Requirement: Receiver(s) must indicate the presence of permission to operate signals without gaps or interruptions over at least a one (1) hour observation period in the presence of an SunSpec-compliant SFSK signal having a compliant duty cycle and an amplitude in the range $V_{RXSENSE}$ mV – V_{RXMAX} mV r.m.s.

5.2.3 Requirement: Receiver(s) must meet the requirements of this specification when tested with SunSpec-compliant signals that are subject to any allowable frequency/timing offset within the tolerances specified in Table 6.

5.2.4 Requirement: Receiver(s) must indicate the absence of permission to operate signals in response to any SunSpec compliant code other than the designated code sequences, which state a permission to operate code specified in Table 6.

5.2.5 Requirement: Receiver(s) including their output leads (defined as the cables that connect the RSD to the PV system. Output leads of the RSD end at the PV connectors used for the string connection.) must have pass-through impedance with absolute values in the range specified for $|Z_i|$ and $|Z_u|$ in Table 6 in the range from 20kHz up to 200kHz both in Active Mode and in Shutdown Mode.

For Multi-module RSD (i.e. SunSpec RSD implementations where modules are connected in series), the passthrough impedance values shall be multiplied by

the maximum quantity of PV modules intended to be used with such an RSD to determine the total impedance.

5.2.6 Requirement: Receiver(s) must indicate the absence of permission to operate signals without any false alarms in the presence of a standardized noise and interference test signal as specified in the SunSpec Rapid Shutdown Compatibility Test Plan.

Informative Note: Manufacturers are advised that Keep Alive code word consistency checking should be implemented so as to guarantee a rate of false alarms of less than one per hundred hours of continuous operation. Methods to achieve this include, but are not limited to, checking the bit pattern match of two or more successive code word triplets ($W_1W_1W_1$) and checking the time interval between them is within acceptable tolerances.

Receiver Out-of-Band Rejection Specifications

The receiver must not be perturbed by signals outside the receive band.

5.2.7 Requirement: Receiver(s) must tolerate the presence of out-of-band signals having rejection ratio values as defined in Table 4: Rejection Ratio Values and depicted in Figure 4: Rejection Ratio Graph, for a sensitivity reduction of no more than 3dB.

Frequency (KHz)	$0 < F \leq 30$	$30 < F \leq 72$	$72 < F \leq 120$	$120 < F \leq 155$	$155 < F \leq 200$	$200 < F \leq 300$	$300 < F \leq 1000$
Rejection (dB)	-50	-40	-20	0	-20	-30	-40

Table 4: Rejection Ratio Values

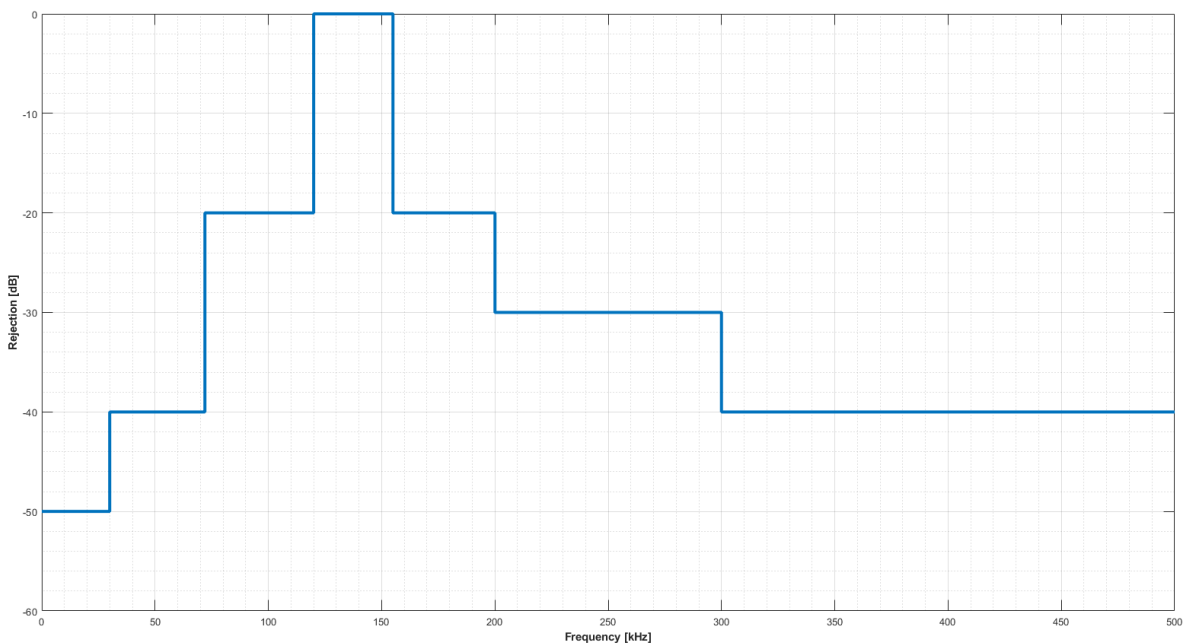

Figure 4: Rejection Ratio Graph

Receiver In-Band Rejection Specifications

The receiver must be able to separate the two carrier frequencies of the FSK modulated RF signal.

5.2.8 Requirement: Receiver must reject in-band signals by values defined in Table 5: In-Band Rejection Values and depicted in Figure 5: In-Band Rejection Graphic.

Rx In-Band Rejection					
F-Fc [kHz]	-50 < F ≤ -9	-9 < F ≤ -3	-3 < F ≤ 3	3 < F ≤ 9	9 < F ≤ 50
RR [dB]	-20	-20	0	-20	-20

Table 5: In-Band Rejection Values

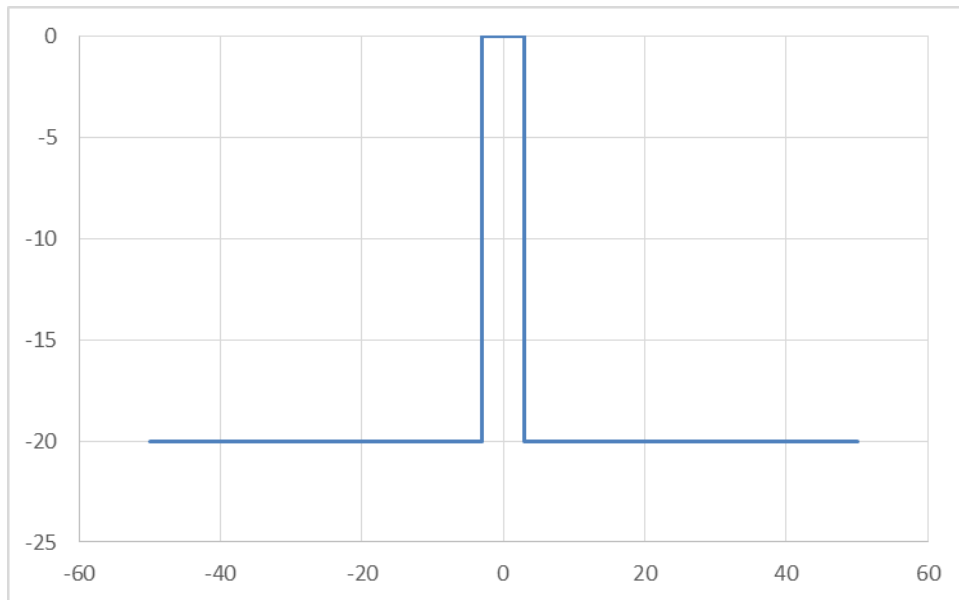
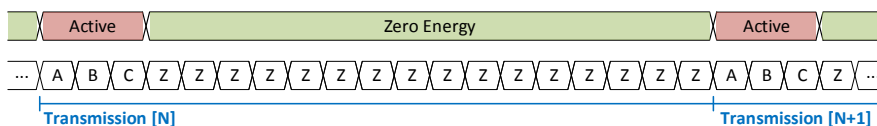

Figure 5: In-Band Rejection Graphic

5.3 PLC Protocol Requirements



Where A, B, & C = W_0 or W_1 :

$$W_1 = \langle -1 \rangle \langle -1 \rangle \langle -1 \rangle \langle +1 \rangle \langle +1 \rangle \langle +1 \rangle \langle -1 \rangle \langle +1 \rangle \langle +1 \rangle \langle -1 \rangle \langle +1 \rangle$$

$$W_0 = \langle +1 \rangle \langle +1 \rangle \langle +1 \rangle \langle -1 \rangle \langle -1 \rangle \langle -1 \rangle \langle +1 \rangle \langle -1 \rangle \langle -1 \rangle \langle +1 \rangle \langle -1 \rangle$$

Where Z = Zero Energy Word:

$$z = \langle 0 \rangle \langle 0 \rangle \langle 0 \rangle \langle 0 \rangle \langle 0 \rangle \langle 0 \rangle \langle 0 \rangle \langle 0 \rangle \langle 0 \rangle \langle 0 \rangle \langle 0 \rangle \langle 0 \rangle$$

Figure 5: Keep Alive Duty Cycle Timing Diagram

The following values and parameter ranges are **Requirements of the Power Line Communication** attributes of this specification.

Symbol	Transmitter Specification	Min.	Nom.	Max.	Unit	Remark
W₁	Logic 1 Code Word	{-1, -1, -1, +1, +1, +1, -1, +1, +1, -1, +1}				+1 = mark, -1=space
W₀	Logic 0 Code Word	{+1, +1, +1, -1, -1, -1, +1, -1, -1, +1, -1}				+1 = mark, -1=space
Z	Zero Energy Word	{0, 0, 0, 0, 0, 0, 0, 0, 0, 0, 0}				0 = zero energy
	Cyclical Transmission	{A, B, C, Z, Z, Z, Z, Z, Z, Z, Z, Z, Z, Z, Z, Z}				A,B,C are W ₀ or W ₁ Z=zero energy word
	Permission To Operate Code	A B C = W ₁ W ₁ W ₁				Mandatory
	Accelerated Shutdown	A B C = W ₀ W ₀ W ₀				Optional
	Proprietary Use 1 Includes permission to operate	A B C = W ₁ W ₀ W ₁				Optional
	Proprietary Use 2 Without permission to operate	A B C = W ₀ W ₁ W ₀				Optional
	Reserved Includes permission to operate	ABC = W ₁ W ₁ W ₀				Do not use
	Reserved Without permission to operate	ABC = W ₀ W ₀ W ₁				Do not use
	Reserved Without permission to operate	ABC = W ₀ W ₁ W ₁				Do not use
	Reserved Without permission to operate	ABC = W ₁ W ₀ W ₀				Do not use
F_M	Mark Frequency	131.236875	131.25	131.263125	kHz	6.25kHz × 21
F_S	Space Frequency	143.735625	143.75	143.764375	kHz	6.25kHz × 23
T_S	Average Bit Period	5.119488	5.12	5.120512	ms	(Time to complete one full duty cycle)/219
T_T	Transmission Period	168.943104	168.96	168.976896	ms	3 Words
T_Q	Quiet Period	901.029888	901.12	901.210112	ms	16 Words
T_C	Cycle Period	1069.972992	1070.08	1070.187008	ms	19 Words

Z_{TX}	Transmitter Output Impedance	0.05		1.5	Ω	
V_{TX}	Transmitter Output Voltage into >100 kΩ	0.9	1.0	1.1	V r.m.s.	
I_{RXMAX}	Receiver Input Current Max	142			mA r.m.s.	
I_{RXSENSE}	Receiver Input Current Minimum Sensitivity			1.20	mA r.m.s.	118:1 dynamic range
 Z_u 	Receiver Line Impedance above 100kHz	--		8	Ω	amount of impedance in upper frequency range
 Z_l 	Receiver Line Impedance from 20kHz up to 100kHz	--		6	Ω	amount of impedance in lower frequency range
Z_{RXM}	Receiver Line Impedance @ F _S and F _M	1	-	-	Ω	minimum impedance required at F _m and F _s
P_{FALSE}	Probability of false detection					Per SunSpec testing

Table 6: Power Line Communication Values

Table Footnotes:

1. Sequences shall be transmitted in left-to-right order {b1, b2, b3... } means bit 1 followed by bit 2, followed by bit 3 etc.
2. Code words are transmitted continuously in a repetitive, cyclical fashion with no extraneous signaling bits nor additional time delay inserted between them.
3. Code sequences without permission to operate can be sent during a Rapid shutdown initiation while code sequences with permission to operate shall only be sent when an initiator indicates rapid shutdown is not active. If there is no functional indication to use any other code sequence with permission to operate, the code sequence A B C = W₁ W₁ W₁ must be used.
4. Reserved code sequences are for future use by this standard.
5. Receiving a code sequence without permission to operate is not an accelerated shutdown and should be treated like there was no permission to operate signal received.
6. All frequencies and durations are subject to ±100 ppm tolerances on their nominal values at the transmitter.
7. Receivers shall perform within SunSpec specification limits for any long-term frequency deviations at the transmitter that lie within the allowable ±100 ppm tolerance.
8. Receivers may assume that transmitted bit rate and Mark/Space tone frequencies are correlated (*i.e.*, derived from the same original clock source).
9. The receiver line impedance for the specified frequency ranges is defined at the connectors of the output leads of the device, under normal operating conditions of the device. The specified sensitivity refers to this specified receiver line impedance.

6 Test Plan Specification

The test plan specification is a separate SunSpec document: *Communication Signal for Rapid Shutdown Test Specification*.

7 Appendix A: References

2014 National Electrical Code, National Fire Protection Association (section 690.12 includes Rapid Shutdown requirements)

2017 National Electrical Code, National Fire Protection Association (section 690.12 includes Rapid Shutdown requirements)

Underwriters Laboratories Standard 1741, *Standard for Inverters, Converters, Controllers and Interconnection System Equipment for Use with Distributed Energy Resources* (draft sections on Rapid Shutdown Equipment and Rapid Shutdown Systems)

Underwriters Laboratories Standard 3741, *Standard for Safety Photovoltaic Hazard Control* (draft sections on Rapid Shutdown Systems)

8 Appendix B: Spread Frequency Shift Keying (S-FSK) Principle

S-FSK is a modulation and demodulation technique combining some of the advantages of a classical spread spectrum system, i. e., immunity against narrowband interferences with the advantages of a classical FSK system, low-complexity, and well-investigated implementations.

The transmitter assigns the space frequency f_S to “data 0” and the mark frequency f_M to “data 1”. The difference between S-FSK and the classical FSK lies in the fact that f_S and f_M are placed far from each other (spreading). By placing f_S far from f_M , their transmission quality becomes independent, i.e., each frequency will have its own attenuation factor and local narrow-band noise spectrum.

The receiver performs conventional FSK demodulation at the two possible frequencies (the half-channels) resulting in two demodulated signals d_S and d_M . If the average reception quality of the two half-channels is similar, then the decision unit decides on the higher of the two demodulated channels (“data 0” if $d_S > d_M$, “data 1” if $d_S < d_M$). If, however, the average reception quality of one half-channel is significantly better than the quality of the other half-channel, then the decision unit compares the demodulated signal of the better channel with a threshold T , thus ignoring the worse channel.

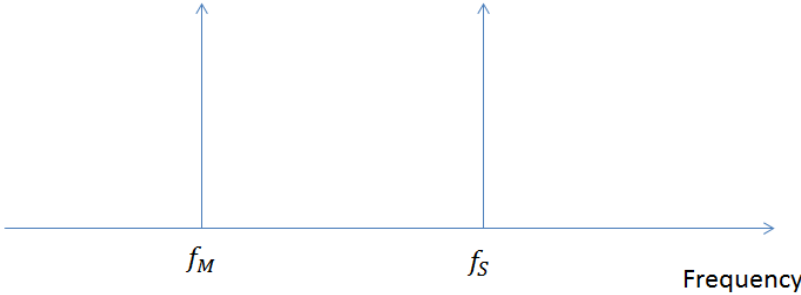

Figure 6: FSK on Frequency Domain

9 Appendix C: Standby Signal

When in shutdown mode, the Receiver(s) providing a low voltage, low current standby signal offer the following advantages:

Reduced power consumption during the night

The presence of the standby signal of the Receivers indicates the presence of daylight. It allows to turn-off the permission to operate signal of the Transmitter overnight and reduces thereby the power consumption of the system.

Ease of installation

The installer can verify the correct polarity, the count of modules per string, the string associated wires etc. without a special tool to inject the permission to operate signal. He has the additional benefit of working on safe voltage levels and limited power.

10 Appendix D: PV System Configuration Limits for The Provided Power Line Communication Values

The provided Power Line Communication Values out of this Specification are based on the following PV System Configuration Limits:

- 6 to 30 modules with Receivers in series
- 1 to 10 strings in parallel per Transmitter
- Minimum wire impedance of 6.4 Ohm @ mark frequency (including module wiring; equates to 7.8 μ H)
- Maximum wire impedance of 234 Ohm @ space frequency (including module wiring; equates to 259 μ H)

11 Appendix E: Multi-module RSD

This specification primarily addresses the case of one RSD connected to a single PV module, i.e. single-module RSD. In case of multi-module RSD with inputs connecting to two or more modules in series, additional requirements are as follows:

1. As indicated in Section 4.3.3, Multi-module RSD does not need to comply with Standby Power requirements. In case of Standby Power is implemented, the following rules apply:

PV Power Source voltage in Shutdown V_{OFF} : the Min V_{OFF} shall be equal to the number of modules multiplied by the value of Min V_{OFF} of a module-level RSD. However, Max V_{OFF} of a string shall not exceed total 30V. E.g., for a multi-module RSD connected to 2 modules, if the maximum number of the RSDs in a string is 15, then the Max V_{OFF} of the RSD is 2V. Similarly, if the number of RSDs in a string is 3, then the Max V_{OFF} of the RSD is 10V.

2. Pass-through impedance: the I-limit is the quantity of modules per RSD multiplied by the I-limit of a single-module RSD. E.g., for a Multi-module RSD connected to 2 modules, the maximum impedance above 100 kHz is 16 ohms, and up to 100 kHz it is 12 ohms. The minimum impedance is 2 ohms at the FS and FM frequencies.