

APPROVED

Version 19

April 20, 2021

Communication Signal for Rapid Shutdown Test Specification



Abstract

This document defines the test requirements and procedure for conducting electrical tests to verify compliance with the *SunSpec Interoperability Specification: Communication Signal for Rapid Shutdown*.

License Agreement and Copyright Notice

THIS DOCUMENT AND THE INFORMATION CONTAINED HEREIN IS PROVIDED ON AN "AS IS" BASIS AND THE SUNSPEC ALLIANCE DISCLAIMS ALL WARRANTIES, EXPRESS OR IMPLIED, INCLUDING BUT NOT LIMITED TO ANY WARRANTY THAT THE USE OF THE INFORMATION HEREIN WILL NOT INFRINGE ANY OWNERSHIP RIGHTS OR ANY IMPLIED WARRANTIES OF MERCHANTABILITY OR FITNESS FOR A PARTICULAR PURPOSE.

THIS DOCUMENT MAY BE USED, COPIED, AND FURNISHED TO OTHERS, WITHOUT RESTRICTIONS OF ANY KIND, PROVIDED THAT THIS DOCUMENT ITSELF MAY NOT BE MODIFIED IN ANYWAY, EXCEPT AS NEEDED BY THE SUNSPEC TECHNICAL COMMITTEE AND AS GOVERNED BY THE SUNSPEC IPR POLICY. THE COMPLETE POLICY OF THE SUNSPEC ALLIANCE CAN BE FOUND AT WWW.SUNSPEC.ORG.

Attribution

This specification was developed by the SunSpec Alliance Communication Signal for Rapid Shutdown Workgroup. This workgroup includes the following individuals and companies:

Sauro Macerini, Giovanni Manchia, Ronnie Pettersson, Robert White, Mirco Mirra, Enrico Pietrantozzi (ABB); Andrew Misenheimer (Aleo Inc.); Devin Cao, Daniel Richardson (Canadian Solar); Anton Fischer (Celestica); Peter Chung, Nick Lee (Delta Products Corp.); John Berdner (Enphase); Martin Beran, Christian Fasthuber, Brian Lydic, Christoph Wolf (Fronius); Bernie Grant, Terence Parker (Ginlong-Solis); Ben Castillo, Bill Reaugh (KACO new energy); Chetan Chaudhari, Seth Kahn, Charles Razzell, Ryan Ricchiuti (Maxim Integrated); Thierry Arnaud, Ali Julazadeh (Mersen); Ryan Stankevitz (Midnite Solar); Ozgur Aksoy (Monitek LLC); Erica Martin (Omron Electronic Components LLC); Andrew Ahmad, Anand Janaswamy (OneRoof Energy); Brian Faley, Philip Undercuffler, Mara White (OutBack Power); Lotte Ehlers, Wolfgang Hoëft (Phoenix Contact); Larry Sherwood (Sherwood Associates); Markus Hopf, Hannes Knopf, Michael Viotto, Thomas Wegener (SMA Solar Technology); Alex Mayer, Sandeep Narla, Jake West (SolarCity); Steve Robbins (Sunfield Semiconductor); Jonathan Ehlmann, Kelly Mekechuk (SunPower); Tom Tansy (SunSpec Alliance); Amneh Akour, Dick Hester, Il Han Kim, Nat Natarajan, Tim Pauletti (Texas Instruments); Gal Bauer, Vered Sharon, Bijay Shrestha, Danny Eizips (Tigo Energy); Chris Flueckiger, Tim Zgonena (UL); Ward Bower (Ward Bower Innovations); Emily Hwang, Aegir Jonsson (Yaskawa Solectria Solar); Ralf Schulze (Yingli).

Contact Information

SunSpec Alliance
4040 Moorpark Avenue, Suite 110
San Jose, CA 95117
info@sunspec.org

Revision History

Revision	Date	Reason
1	12-14-2016	First Draft in SunSpec Template
2	01-04-2017	Revised the Test signal timing and waveform accuracy in Section 2.2.1
3	02-07-2017	Update of receiver sensitivity and maximum level +
4	02-22-2017	Revised definition of SunSpec Signal Generator in Section 3.1 Added Appendix B Changes incorporated in Sections 2.2.3, 2.2.4, 3.2.2, 3.2.3, 3.2.4
5	03-01-2016	Minor edits and accepted changed to produce a clean draft document.
6	03-15-17	Section 2.2.2 – fixed mistake in output impedance of the DUT Table 5.1 – set time for start-up to 15 seconds
7	03-21-17	Copy editing and layout clean up. Revise Section 3.2.4
8	04-26-17	Timing language revised in Section 5.1
9	6-13-17	Update of section 3.2.1 to adapt the test specification to Rev31 od the signal specification Updated figure 5.1 in part 5.1 with the specified timing
10	08-21-17	Revised status to APPROVED
11-17	02-23-21 to 03-02-21	Changes introduced to support multi-module implementations, coexistence with arc fault detection on the power line, and to clarify existing requirements
18	03-09-21	Incorporated formatting changes Set status to TEST Published PDF version for review and comment by all SunSpec Alliance members
19	04-20-21	Set status to APPROVED

About the SunSpec Alliance

The SunSpec Alliance is a trade alliance of developers, manufacturers, operators and service providers, pursuing open information standards for the Distributed Energy industry. SunSpec Alliance standards address operational aspects of PV, storage and Distributed Energy power plants on the smart grid—including residential, commercial, and utility-scale systems— thus reducing cost, promoting innovation, and accelerating industry growth.

Global leaders from Asia, Europe, and North America are members of the SunSpec Alliance. Membership is open to corporations, non-profits, and individuals. For more information about the SunSpec Alliance, or to download SunSpec specifications at no charge, please visit www.sunspec.org.

About the SunSpec Specification Process

SunSpec Alliance specifications are developed by SunSpec member companies seeking to establish industry standards for mutual benefit. Any SunSpec Alliance member can propose a technical work item. Given sufficient interest and time to participate, and barring significant objections, a workgroup is formed. Workgroups meet regularly to advance the agenda of the team.

The output of a workgroup is a SunSpec interoperability specification. SunSpec interoperability specifications are considered to be normative, meaning that there is a matter of conformance required to support interoperability. The revision and associated process of managing these documents is tightly controlled. Other SunSpec documents are informative, and provide recommendations regarding best practices, but are not a matter of conformance. Informative documents can be revised more freely and frequently to improve the quality and quantity of information provided.

SunSpec interoperability specifications follow this lifecycle pattern of DRAFT, TEST, APPROVED and SUPERSEDED.

For more information or to download a SunSpec Alliance specification, go to <http://sunspec.org/about-sunspec-specifications/>.

Table of Contents

1.	Introduction	0
2.	Transmitter electrical test specification	1
2.1.	Principle of transmitter electrical test	1
2.2.	Transmitter electrical performance test.....	1
2.2.1.	Modulation accuracy test	1
2.2.2.	Transmitter output level test and transmitter output impedance:	4
2.2.3.	Transmitter in band spurious emission test.....	4
2.2.4.	Transmitter out of band spurious emission test	5
3.	Receiver electrical test specification	7
3.1.	Principle of receiver test.....	7
3.2.	Receiver electrical performance tests	10
3.2.1.	Receiver input range electrical test	10
3.2.1.1.	Receiver input sensitivity.....	10
3.2.1.2.	Receiver maximum input level	11
3.2.2.	Receiver in-band interferer rejection	12
3.2.3.	Receiver out-of-band interferer rejection:.....	13
3.2.4.	Receiver impedance tests	15
3.2.4.1.	Receiver impedance in OFF state at Fmark and Fspace.....	15
3.2.4.2.	Receiver impedance in ON state at Fmark and Fspace	16
3.2.4.3.	Receiver impedance in ON state in the 20 kHz - 200 kHz range.....	17
3.2.5.	Receiver shutdown output voltage test	18
3.2.6.	Test setup 1 – powered by PV module	18
3.2.7.	Test setup 2 – powered with DC sources	18
3.2.8.	Test procedure	19
3.2.9.	Measurement equipment	19
4.	Equipment interoperability test specification	20

4.1.	Technical Interoperability definition	20
4.2.	The prerequisite to interoperability test:	20
4.3.	Symptoms of interoperability and non-interoperability:	20
4.4.	Overall interoperability test framework:	22
5.	Interoperability test sequences	24
5.1.	Start Process interoperability test: single receiver	24
5.2.	Stop Process interoperability test: single receiver	25
5.3.	Repeated Start and Stop interoperability test: single receiver	26
5.4.	Multiple receiver interoperability test:	28
APPENDIX A: Signal Timing and Waveform Accuracy		30
APPENDIX B: Simulating Additional Receiver or Parallel Strings		32

References:

[1] “Communication Signal for Rapid Shutdown: SunSpec Interoperability Specification”

1. Introduction

The purpose of this document is to define a test procedure to check the compliance of equipment with the SunSpec Communication Signal for Rapid Shutdown specification. Checking the compliance of equipment is done in two steps:

- The equipment will be first tested according to the electrical specification defined by SunSpec either as a transmitter or a receiver
- A second functional test of inter-operability between equipment from various suppliers can then be performed

Section 2 of this document covers the transmitter electrical test.

Section 3 of this document covers the receiver electrical test.

Section 4 of this document defines the interoperability test process.

Section 5 of this document defines the interoperability test sequences.

Operating temperature conditions: electrical parameters shall be checked at temperatures specified by the manufacturer.

2. Transmitter electrical test specification

2.1. Principle of transmitter electrical test

This part of the test specification refers to paragraphs 5.1 and 5.3 of the document “Communication Signal for Rapid Shutdown: SunSpec Interoperability Specification” [1]

The purposes of the test of the transmitter are the following:

- Test the modulation accuracy of the transmitter according to table 6 of paragraph 5.3 of [1]
- Test the output level and impedance of the transmitter according to table 6 of paragraph 5.3 of [1]
- Test the output spectrum of the transmitter according to paragraph 5.1 of [1]

Figure 2.1 gives a generic test environment for the test of the transmitter:

- DUT is the transmitter device that has to be tested
- Enabling equipment is the equipment necessary to put the transmitter in operation but not influencing the key electrical parameters of the transmitter (it could be external power supplies for the transmitter, equipment to simulate the voltage of a PV string if the transmitter is part of an inverter, ...)
- Test equipment is the equipment that will be used to extract the electrical parameter that has to be tested.
- Load is a reference component on which the transmitter delivers its signal and on which the test equipment extracts the electrical parameter that has to be checked.

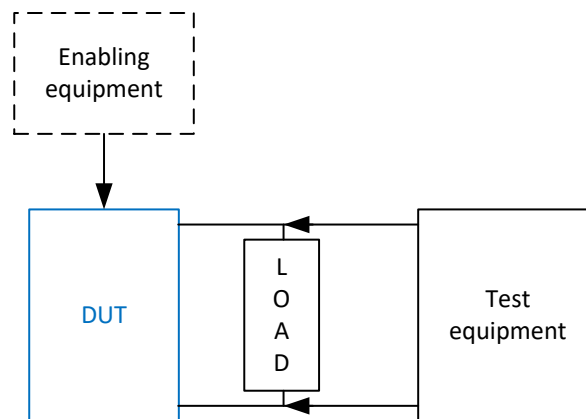

Figure 2.1: Transmitter test configuration

2.2. Transmitter electrical performance test

2.2.1. Modulation accuracy test

The reference for this test is table 6 of paragraph 5.3 of [1]

Test of the frequency accuracy: the test is performed according to figure 2.2.

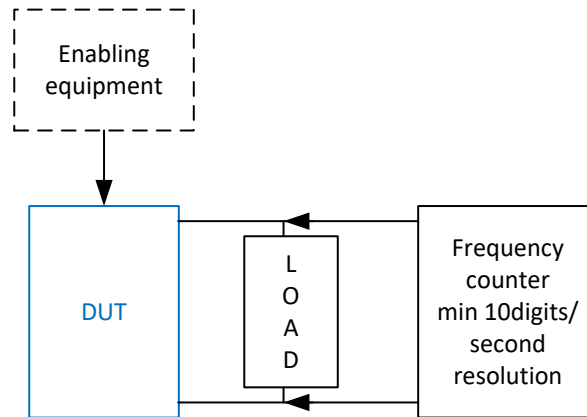

Figure 2.2: Test of frequency accuracy

For the test of the frequency accuracy, we propose a test mode to be implemented in the product embedding the transmitter device in order to send a permanent signal at FM or FS. In this mode, the transmitter is connected to a one (1) Ohm load resistor. The frequency counter checks the accuracy of FM and FS frequencies of the keep alive signal on the load resistor according to table 2.1.

Symbol		Min.	Typ.	Max	Unit
FM	Mark Frequency	131.236875	131.25	131.263125	kHz
FS	Space Frequency	143.735625	143.75	143.764375	kHz

Table 2.1: frequency accuracy

Test of the signal timing and waveform accuracy: the test is performed according to figure 2.3.

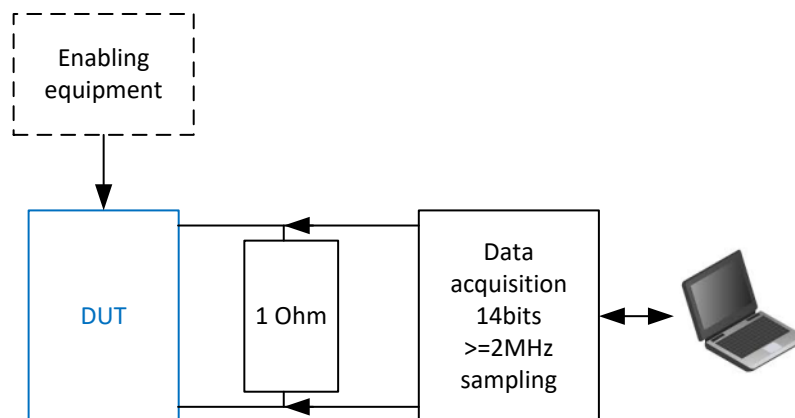

Figure 2.3: Test of signal timing accuracy

The tested transmitter is configured to generate a permission to operate signal with the following sequence: W1,W1,W1,Z,Z,Z,Z,Z,Z,Z,Z,Z,Z,Z,Z,Z and is connected to a 1 Ohm load resistor. The output of the DUT shall be digitized at a sample rate of at least 2MHz and bit depth of at least 12 bits, for a duration of not less than 10 seconds. Post processing of the captured samples shall be used to determine the timing of successive Keep-Alive sequences during the capture interval, using cross-correlation methods.

The post-processing steps from the captured data shall comprise the following operations:

1. Demodulation of the FSK data to a baseband NRZ signal proportional to the transmitted bit values at the same sample rate as the original capture. This NRZ signal shall be truncated to an integer number of duty-cycle periods at the desired sample rate, e.g., 9 whole duty cycles.
2. Performing a circular, normalized cross-correlation of the NRZ demodulated waveform from step #1, with an ideal waveform template consisting of the sequence {W1, W1, W1} that has been zero-padded to the same length as the demodulated NRZ signal.
3. Searching for all correlation peaks with a correlation coefficient of >0.9, and verifying their peak locations and magnitudes.

Mathematical Detail:

Demodulation of the captured waveform shall be accomplished by subtracting the magnitude of the output of a matched filter at the mark-tone frequency from the magnitude a matched filter at the space-tone frequency, where both matched filters take their inputs from the entire vector of captured data. This may be written as:

$$d_k = \left| \sum_{i=0}^N M_{b_k} \cdot x_{n-i} \right| - \left| \sum_{i=0}^N S_{b_k} \cdot x_{n-i} \right|,$$

where $\{M_{b_k}\}$ are the complex coefficients of the mark-tone matched filter, and $\{S_{b_k}\}$ are the complex coefficients of the space-tone matched filter and $\{x_i\}$ are discrete samples of the captured waveform.

The samples of $\{d_k\}$ shall be truncated to a length of nine duty cycle periods, such that its length is $N = 9 \times 11 \times 3 \times F_s \times T_b$ samples, where F_s is the sample rate and T_b is the bit duration. Let the resultant vector be notated as \mathbf{d} .

Let the ideal waveform template representing the sequence {W1, W1, W1}, be notated as a vector \mathbf{w} , having $M = 11 \times 3 \times F_s \times T_b$ non-zero samples, but padded with zeros to length N . Further, let the periodic summation of \mathbf{w} with a period of N be notated as \mathbf{w}_N .

The required circular correlation can now be written as:

$$\mathbf{r} = \sqrt{L} \cdot \frac{(\mathbf{d} \star \mathbf{w}_N)}{\|\mathbf{d}\| \times \|\mathbf{w}\|},$$

where L is the number of duty cycle periods (i.e., the expected number of correlation peaks), \star is the correlation operator and $\|\cdot\|$ represents the norm of its vector argument. The resultant vector \mathbf{r} has N samples, the same length as vector \mathbf{d} .

Based on the convolution theorem, the equivalent result can be obtained as follows:

$$\mathbf{r} = \frac{\sqrt{L}}{\|\mathbf{d}\| \times \|\mathbf{w}\|} (\mathcal{F}^{-1}\{\mathcal{F}\{\mathbf{d}\} \cdot (\mathcal{F}\{\mathbf{w}\})^*\}).$$

Where $(\cdot)^*$ means complex conjugation, $\mathcal{F}\{\mathbf{x}\}$ is the Fourier transform of the vector \mathbf{x} , and $\mathcal{F}^{-1}\{\mathbf{X}\}$ the inverse Fourier transform and $\mathbf{X} \cdot \mathbf{Y}$ represents element-wise multiplication of two vectors.

The following limits shall be verified:

1. The timing interval errors (TIEs) assessed by the locations of at least 8 correlation peaks relative to the first detected correlation peak shall not exceed ± 100 ppm of the respective measured time intervals.
2. The correct number of correlation peaks shall be detected for a given data set size given by the number of whole duty-cycle periods included in the capture. (Nine peaks are expected.)
3. The correlation coefficient for each detected peak shall exceed 0.99 (99%).

2.2.2. Transmitter output level test and transmitter output impedance:

The reference for this test is table 6 of paragraph 6.3 of [1]

The tested transmitter is configured to generate a permission to operate signal with the following sequence:

W1,W1,W1,Z,Z,Z,Z,Z,Z,Z,Z,Z,Z,Z,Z,Z,Z,Z,Z.

- This test is performed according to figure 2.4 by varying the load resistor on the DUT and checking the signal level at frequency FM and FS on the spectrum analyzer according to table 2.3.
- To check the transmitter maximum output dynamic, the load resistor is set to 100kOhms.
- To check the output impedance the load resistor is set to 1 Ohm and the min and max output level measured on the spectrum analyzer assumes that the output impedance of the DUT varies between 0.05 Ohms and 1.5 Ohms.

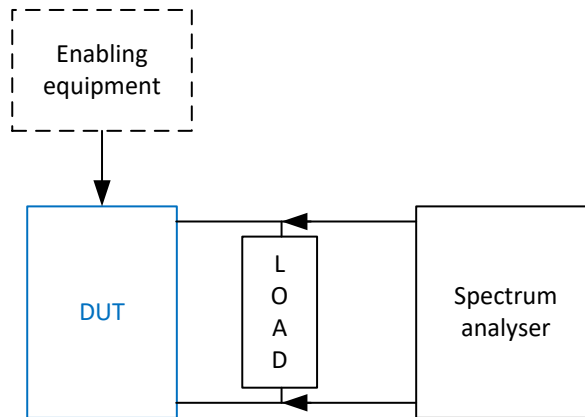

Figure 2.4: Transmitter output level test

Symbol		Min.	Typ.	Max	Unit	Comment
VTX	high load output swing	0.9	1	1.1	Vrms	Rload=100kOhms
Vload	transmitter compliance	0.36		1.05	Vrms	Rload=1Ohms --> calculate transmitter output impedance

Table 2.3: Transmitter output level and output impedance test

2.2.3. Transmitter in band spurious emission test

The reference for this test is paragraph 5.1.10 of [1]

The tested transmitter is put in test mode as proposed in part 2.2.1 and configured to generate a single frequency signal at FM or FS. The test is performed according to figure 2.6, and the measured spectrum on the

output of the DUT shall fulfill the mask defined at figure 2.5. The two mark and space signals at FM and FS are taken as the reference level (0dBc) in the spectrum mask of figure 2.5.

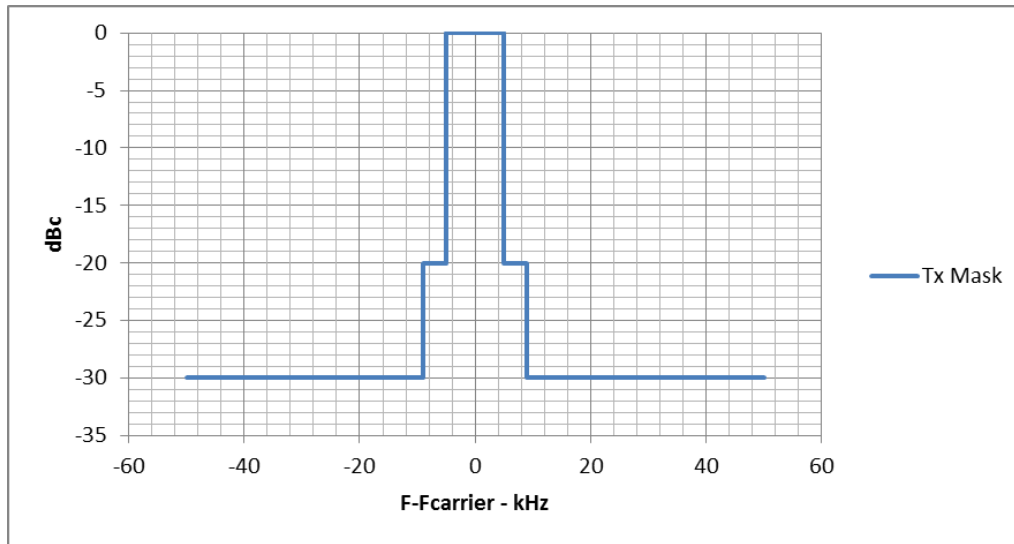

Figure 2.5: Transmitter in band spurious emission mask

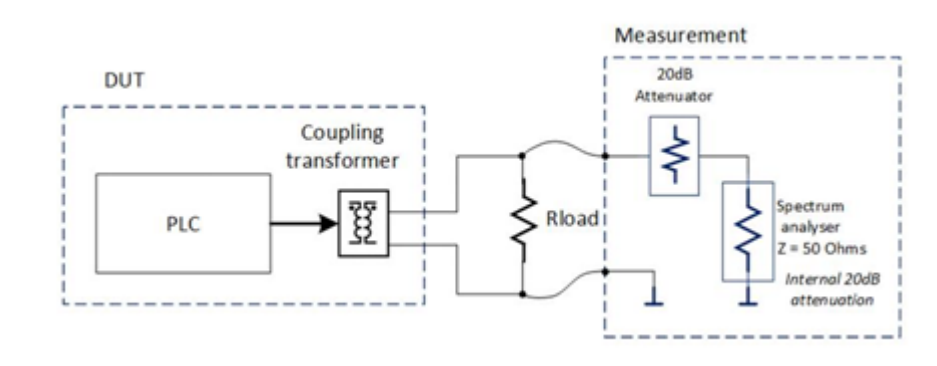

Figure 2.6: Schematic for in band and out of band test

For in band emission test, the following configuration shall be used:

- The mark or space frequency are sent separately (a test mode needs to be implemented as defined in the compliance test specification)
- Rload is set to 10 Ohms
- Spectrum analyzer attenuation : 40dB (20+20)
- Frequency span : centered on the PLC frequencies, frequency span 60kHz or more
- Detection method : positive peak detector
- Resolution bandwidth : 30Hz or less

2.2.4. Transmitter out of band spurious emission test

The reference for this test is paragraph 5.1.9 of [1]

The test is performed according to figure 2.6 and the measured spectrum on the output of the DUT should fulfill the mask defined at figure 2.7. In order to measure only the contribution of the transmitter to the out of band spectrum, the PV inverter could be switched off during this test.

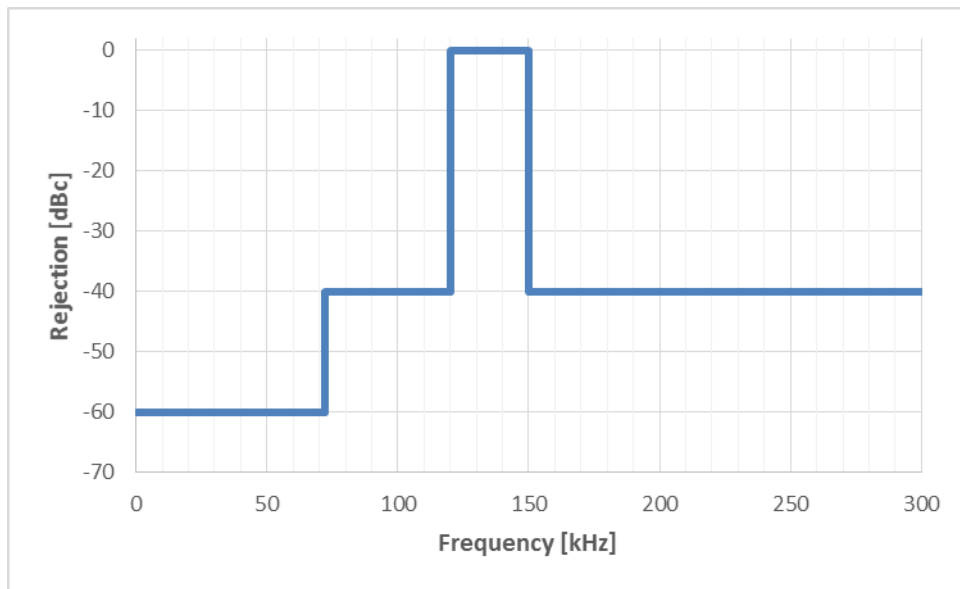

Figure 2.7: Transmitter out of band spurious emission mask

For out of band emission test the following test configuration shall be used:

- The PLC signal is sent continuously (in test mode, W1 is sent continuously)
- Rload is set to 10 Ohms
- Spectrum analyzer attenuation: 40dB
- Detection method: positive peak detector
- Start frequency: 50kHz or less
- Stop frequency: 500kHz or more
- Resolution bandwidth: 30Hz or less
- Video bandwidth: 10Hz or less

3. Receiver electrical test specification

3.1. Principle of receiver test

This part of the test specification refers to paragraphs 5.2 and 5.3 of the document “Communication Signal for Rapid Shutdown: SunSpec Interoperability Specification” [1]

The purposes of the test of the receiver are the following:

- Test the sensitivity level and the maximum input signal level acceptable on the receiver to *indicate the presence* of a permission to operate signal according to requirement 5.2.2 and to table 6 of paragraph 5.3 of [1]
- Test the capability of the receiver to *indicate the absence* of a keep alive signal in presence of a signal compliant with any other SunSpec compliant code other than the permission to operate signal according to requirement 5.2.4 and to table 6 of paragraph 5.3 of [1]
- Test the capability of the receiver to *indicate the presence* of a permission to operate signal according to requirement 5.2.2 and to table 6 of paragraph 5.3 of [1] in presence of both in-band and out of band interferers as defined in part 5.2.7 of [1]
- Test the capability of the receiver to *indicate the absence* of a permission to operate signal according to requirement 5.2.2 and to table 6 of paragraph 5.3 of [1] in presence of both in-band and out of band interferers as defined in part 5.2.6 of [1]

Informative note:

As the Receiver is not always accessible in the RSD (Rapid Shut-down Device), it cannot be tested alone, so instead, the whole RSD is tested, as shown in Figure 3.1.

For in-band and out-of-band interference tests, the major point to be tested is the de-sensitization of the receiver due to blocking interferers. It is also considered that intermodulation products have less impact than blocking signals on the performance of the receiver. The interferer rejection test is done through single tone interferers coupled at the input of the receiver. In that way it is possible to validate in a single test the linearity of the receiver and the performance of the digital demodulator in the presence of interfering signals.

Figure 3.1 gives an example test set up for the test of the receiver, in case of a single-module RSD:

- RSD is the receiver device to be tested
- Enabling Equipment is the equipment necessary to put the receiver in operation but not influencing its key communication electrical parameters (it could be external power supplies, equipment to simulate the voltage of a PV module if the receiver is attached or embedded in a PV module, ...)
- SunSpec signal pattern generator is piece of equipment able to generate a signal compliant with table 6 of paragraph 5.3 of [1] both for the permission to operate signal, and also other codes defined in table 6. This reference signal generator shall be able to deliver powerful enough signals in

order to test the receiver at maximum output voltage. This signal generator can be a suitably buffered arbitrary waveform generator configured to operate at a sample rate of at least 400kHz and having a memory depth sufficient to store an entire SunSpec duty cycle period of 1.07008 seconds. No matter how it is constructed, the SunSpec signal pattern generator must be verified to pass the Transmitter electrical performance tests specified in section 2.2 of this document.

- Single tone generator is a programmable signal generator to test both in-band and out-of-band spurious rejection of the receiver.
- Indicator is the way the receiver indicates that it has decoded or not a permission to operate signal as defined in requirements 5.2.2 and 5.2.4 of [1]

An RSD with multiple inputs shall be tested with identical supply circuits connected to its inputs. Figure 3.2 depicts the example of the test setup with a multi-module RSD with two modules.

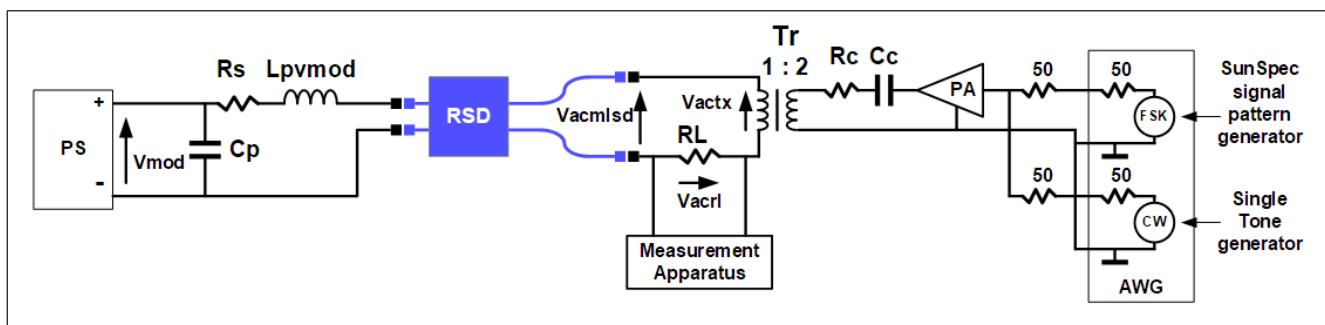

Figure 3.1: Receiver test configuration in case of a single-module RSD

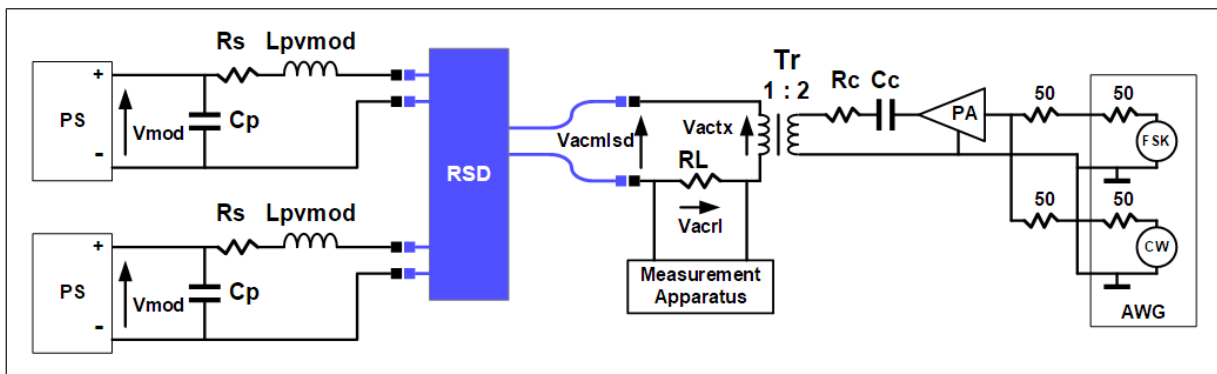

Figure 3.2: Receiver test configuration in case of a multi-module RSD

Table 3.1 shows a description of the components and their mandatory values of Figure 3.1 and Figure 3.2.

PS		Voutmax \geq rated voltage of RSD input Ioutmax \geq rated current of RSD input Pmax \geq 600 W per RSD input
Cp	\geq 100 μ F / 100 V +/- 20%	PS, Cp and Rs are simulating a high power, low impedance PV module
Rs	1 ohm / 250 W +/- 5%	
Lpvmod	5 μ H / 20 A +/- 10%	Typical inductance of a PV module with its cables
AWG	e.g. Teledyne T3AFG40	Arbitrary Waveform Generator with two independent outputs, generates the PLC test signals
PA		Power Amplifier, 10 - 500 kHz, capable of driving 4 ohm with an amplitude of 6 V peak-to-peak (2.25 W)
Tr	1 : 2 Isat \geq Imax Lpri \geq 4 μ H +/- 10%	Signal transformer, Fsig: 10 - 500 kHz Imax is the rated current of DUT
RL	Tolerance: +/- 1% in its whole operating Temperature range	DC load - its resistance value and rated power is chosen according to the operating point of the RSD - see in the following paragraphs. Reactance XL at 200kHz of the load resistor RL must be limited to 10% of the nominal resistance of RL, with XL = 2$\cdot$$\pi$$\cdotF\cdot$LL , where LL is the inductance of RL
Rc	3.9 ohm +/- 1% P \geq 5 W	Coupling between PA and Tr
Cc	22 μ F / 25 V +/- 10%	
Vactx		PLC signal amplitude at Tr primary winding
Vacr1		PLC signal amplitude on RL
VacRSD		PLC signal amplitude at RSD output
Measurement Apparatus	Precision: +/- 1%	Oscilloscope or other Data Acquisition equipment to measure signal amplitude

Table 3.1: Receiver test equipment components

3.2. Receiver electrical performance tests

3.2.1. Receiver input range electrical test

The references for this test are paragraphs 5.2 and 5.3 of [1].

The purpose of this test is to check the sensitivity level and the maximum input signal level acceptable at the receiver input to *indicate the presence* of a permission to operate signal. It is also to test the capability of the receiver to *indicate the absence* of a keep alive signal in presence of a signal compliant with any SunSpec code other than the permission to operate pattern.

3.2.1.1. Receiver input sensitivity

The test is performed according to figure 3.1. As the impedance may depend on the voltage and current applied to the RSD, two measurements shall be taken: Test-1 with voltages close to the rated maximum input voltage ($0.9 * V_{max}$) of the RSD applied to the inputs and Test-2 with a load current close to the rated maximum ($0.8 * I_{max}$) of the RSD. **Ninp** is the number of PV modules connected to the RSD (Figure 3.2). The test procedure is the following:

Test-1:

1. PS is set to $V_{mod} = 0.9 * V_{max}$, $I_{limit} = 1.2 * P_{max} / V_{mod}$
where $P_{max} = 600 \text{ W}$ or the rated power at one RSD input if it is lower
2. $RL = N_{inp} * (V_{mod}/I_{test} - R_s)$, $Pr > I_{test}^2 * RL$
where N_{inp} is the number of inputs, $I_{test} = P_{max} / V_{mod}$ and Pr is the rated power of RL
3. the SunSpec Keep-Alive signal is loaded in AWG Ch-1
4. the AWG Ch-1 amplitude is set to 10 mVp-p, Ch-2 amplitude is set to 0
5. the Ch-1 amplitude is increased gradually until the RSD is switched ON and remains in a stable ON-state
6. the **Vmark** and **Vspace** amplitudes (see Figure 3.3) are measured on the 'MARK' and 'SPACE' portions of the PLC signal across RL - the higher value is used to calculate the sensitivity

As the sensitivity is defined as an RMS value and V_{mark} , V_{space} are measured from peak to peak, the sensitivity level is calculated the following way:

$$I_{sens}(V_{max}) = \max(V_{mark}, V_{space}) / \sqrt{8} / RL$$

Test-2:

1. PS is set to $V_{mod} = P_{max} / I_{test}$, $I_{limit} = I_{max}$
where I_{max} is the rated maximum current of the RSD, $I_{test} = 0.8 * I_{max}$
and $P_{max} = 600 \text{ W}$ or the rated power per RSD input if it is lower
2. $RL = N_{inp} * (V_{mod}/I_{test} - R_s)$, $Pr > I_{test}^2 * RL$

3. Steps 3 to 6 are the same as for Test-1

$$I_{\text{sens}}(I_{\text{max}}) = \max(V_{\text{mark}}, V_{\text{space}}) / \sqrt{8} / R_L$$

The final Isens value is then:

$$I_{\text{RXSENSE}} = \max(I_{\text{sens}}(V_{\text{max}}), I_{\text{sens}}(I_{\text{max}}))$$

The test PASSES if $I_{\text{RXSENSE}} \leq 1.2 \text{ mA r.m.s.}$ - see Table 6 of [1]

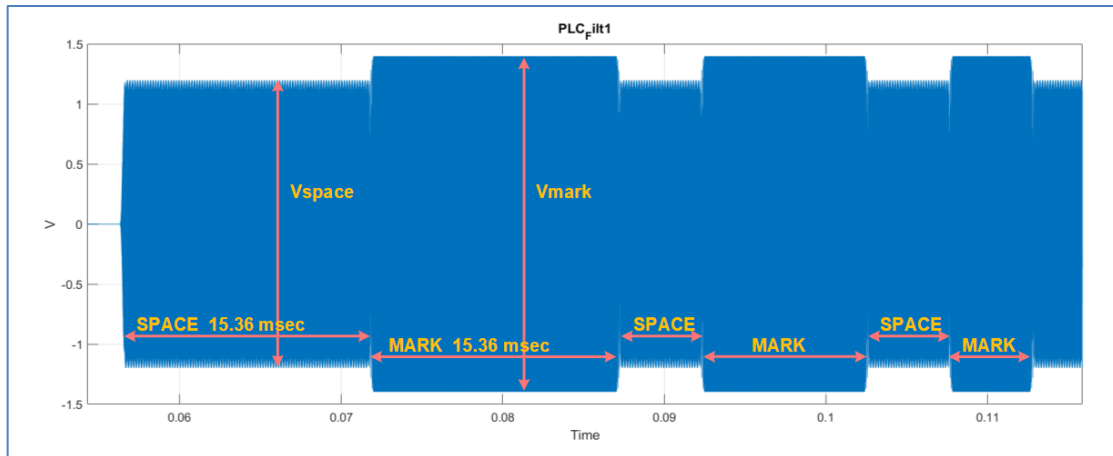

Figure 3.3: SunSpec RSD PLC signal

3.2.1.2. Receiver maximum input level

The test shall be performed according to figure 3.1. As the impedance may depend on the voltage and current applied to the RSD, two measurements shall be taken: Test-1 with voltages close to the rated maximum input voltage ($0.9 * V_{\text{max}}$) of the RSD applied to the inputs and Test-2 with a load current close to the rated maximum ($0.8 * I_{\text{max}}$) of the RSD. **Ninp** is the number of PV modules connected to the RSD (Figure 3.2). The test procedure is the following:

Test-1:

1. PS is set to $V_{\text{mod}} = 0.9 * V_{\text{max}}$, $I_{\text{limit}} = 1.2 * P_{\text{max}} / V_{\text{mod}}$
where $P_{\text{max}} = 600 \text{ W}$ or the rated power at one RSD input if it is lower
2. $R_L = N_{\text{inp}} * (V_{\text{mod}} / I_{\text{test}} - R_s)$, $P_r > I_{\text{test}}^2 * R_L$
where N_{inp} is the number of inputs, $I_{\text{test}} = P_{\text{max}} / V_{\text{mod}}$ and P_r is the rated power of R_L
3. the SunSpec Keep-Alive signal is loaded in AWG Ch-1
4. the AWG Ch-1 amplitude is set to 100 mVp-p, Ch-2 amplitude is set to 0
5. the Ch-1 amplitude is increased gradually until the RSD is switched OFF
6. the **Vmark** and **Vspace** amplitudes (see Figure 3.3) are measured on the 'MARK' and 'SPACE' portions of the PLC signal across R_L - the lower value is used to calculate the maximum input level

As the input level is defined as an RMS value and Vmark, Vspace are measured from peak to peak, the maximum level is calculated the following way:

$$I_inmax(Vmax) = \min(Vmark, Vspace) / \sqrt{8} / RL$$

Test-2:

1. PS is set to $Vmod = Pmax / I_{test}$, $I_limit = I_{max}$
where I_{max} is the rated maximum current of the RSD, $I_{test} = 0.8 * I_{max}$
and $Pmax = 600$ W or the rated power per RSD input if it is lower
2. $RL = Ninp * (Vmod/I_{test} - Rs)$, $Pr > I_{test}^2 * RL$
3. to 6. are the same as for Test-1

$$I_inmax(I_{max}) = \min(Vmark, Vspace) / \sqrt{8} / RL$$

The final maximum level is then:

$$I_{RXMAX} = \min(I_inmax(Vmax), I_inmax(I_{max}))$$

The test PASSES if $I_{RXMAX} \geq 142$ mA r.m.s. - see Table 6 of [1]

3.2.2.Receiver in-band interferer rejection

The test shall be performed according to figure 3.1 (or 3.2 for multi-module RSDs). The interfering signal is a CW tone sent with a varying frequency between 120kHz and 155kHz according to table 3.2 and Figure 3.4.

It has to be noted that CW blockers at FM and FS are included in this test. The goal is to test that the architecture of the receiver is immune to any single tone blocking signal right at FS or FM.

Note: as the receiver input signal is defined as a current, all the signal values and measurement methods remain unchanged in case of multi-module RSDs

Two tests shall be performed to test the in-band interferer rejection of the receiver:

Test-1: ON-state, the RSD must stay ON in the presence of interferer. The level of the SunSpec test pattern is measured on the RL load resistor (see Figure 3.1) at FS and FM and is set at $I_{RXSENSE} +3$ dB i.e. 1.7 mArms or -55.4 dBArms. The test procedure is the following:

1. PS is set to $Vmod = 20$ V, $RL = 10$ ohm, $Pr \geq (Ninp * Vmod)^2 / RL$, where $Ninp$ is the number of inputs of the RSD
2. the SunSpec Keep-Alive signal is loaded in AWG Ch-1, its amplitude is set to 10 mV
3. Ch-1 amplitude is increased gradually until $V_{acrl} = 1.7$ mV * $\sqrt{8}$ * $RL = 48.1$ mVp-p;
→ the RSD goes to ON state
4. AWG Ch-2 is set to Continuous Wave (CW)

5. for each frequency in Table 3.2, AWG Ch-2 amplitude is set so that Vacrl equal the corresponding value. Vacrl is measured between the FSK bursts, as shown in Figure 3.6

The test PASSES if at each CW frequency the RSD stays in ON-state

F - kHz	120	121.25	122.5	123.75	125	126.25	127.5	128.75	130	131.25	132.5	133.75	135	136.25	137.5
Level - mA r.m.s.	17	17	17	17	17	17	17	1.7	1.7	1.7	1.7	1.7	17	17	17
Vacrl (RL = 10 ohm)	481	481	481	481	481	481	481	48.1	48.1	48.1	48.1	48.1	481	481	481
F - kHz	138.75	140	141.25	142.5	143.75	145	146.25	147.5	148.75	150	151.25	152.5	153.75	155	
Level - mA r.m.s.	17	17	1.7	1.7	1.7	1.7	1.7	17	17	17	17	17	17	17	
Vacrl (RL = 10 ohm)	481	481	48.1	48.1	48.1	48.1	48.1	481	481	481	481	481	481	481	

Table 3.2: In-band interferer frequency and signal levels

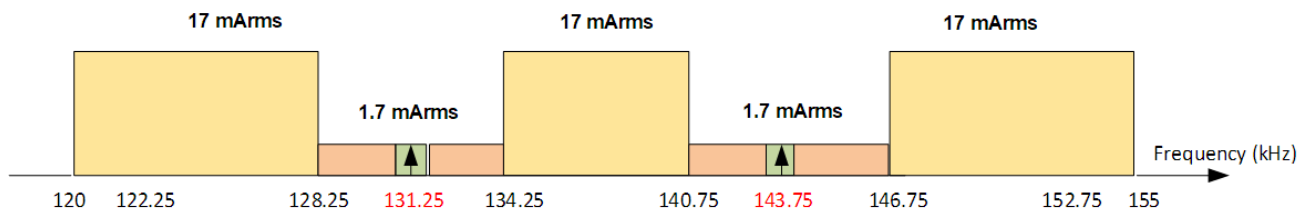

Figure 3.4: In-band interferer rejection test levels

Test-2: OFF-state, the RSD must stay OFF in the presence of interferer. The interferer signal level shall be measured on the RL load resistor (see Figure 3.1). The test procedure is the following:

1. PS is set to $V_{mod} = 20\text{ V}$, $RL = 10\text{ ohm}$, $Pr \geq (N_{inp} * V_{mod})^2 / RL$, where N_{inp} is the number of inputs of the RSD
2. the SunSpec Keep-Alive signal on AWG Ch-1 is stopped
3. AWG Ch-2 is set to Continuous Wave (CW)
4. for each frequency in Table 3.2, AWG Ch-2 amplitude is set so that Vacrl equal the corresponding value. Vacrl is measured between the FSK bursts, as shown in Figure 3.6

The test PASSES if at each CW frequency the RSD stays in OFF-state

3.2.3.Receiver out-of-band interferer rejection:

The test shall be performed according to Figure 3.1 (or 3.2 for multi-module RSDs). The interfering signal is a CW tone sent with a varying frequency between 30 kHz and 500 kHz according to table 3.3 and Figure 3.5.

Note-1: as the receiver input signal is defined as a current, all the signal values and measurement methods remain unchanged in case of multi-module RSDs.

Note-2: [1] specifies the out-of-band interferer between 0 and 1000 kHz. For practical reasons, the test is done in the 30 - 500 kHz range. This is justified by the following:

- The interferer level is 540 mA r.m.s. i.e. 764 mA peak below 30 kHz, impossible to generate with the test setup of Figure 3.1. Assuming that the receiver input stage is a parallel resonator, it represents an inductive impedance below 30 kHz, so the voltage level resulting from the signal current is low, the receiver is very unlikely to be saturated.
- The inductive cable impedance becomes high above 500 kHz, it is impossible to generate the 170 mA r.m.s. i.e. 240 mA peak interferer with the test setup of Figure 3.1

Two tests shall be performed to test the out-of-band interferer rejection of the receiver:

Test-1: ON-state, the RSD must stay ON in the presence of interferer. The level of the SunSpec test pattern is measured on the RL load resistor (see Figure 3.1) at FS and FM and is set at $I_{RXSENSE} +3$ dB i.e. 1.7 mArms or -55.4 dBArms. The test procedure is the following:

1. PS is set to $V_{mod} = 20$ V, $R_L = 10$ ohm, $P_r \geq (N_{inp} * V_{mod})^2 / R_L$, where N_{inp} is the number of inputs of the RSD
2. the SunSpec Keep-Alive signal is loaded in AWG Ch-1, its amplitude is set to 10 mV
3. Ch-1 amplitude is increased gradually until $V_{acrl} = 1.7$ mV * $\sqrt{8}$ * $R_L = 48.1$ mVp-p; the RSD goes to ON state
4. AWG Ch-2 is set to Continuous Wave (CW)
5. for each frequency in Table 3.3, AWG Ch-2 amplitude is set so that V_{acrl} equal the corresponding value. V_{acrl} is measured between the FSK bursts, as shown in Figure 3.6

The test PASSES if at each CW frequency the RSD stays in ON-state

F - kHz	30	40	50	60	70	80	90	100	110
Level - mA r.m.s.	170	170	170	170	170	17	17	17	17
Vacrl (RL = 10 ohm)	4810	4810	4810	4810	4810	481	481	481	481
F - kHz	160	170	180	190	200	250	300	400	500
Level - mA r.m.s.	17	17	17	17	54	54	54	170	170
Vacrl (RL = 10 ohm)	481	481	481	481	1530	1530	1530	4810	4810

Table 3.3: Out-of-band interferer frequency and signal levels

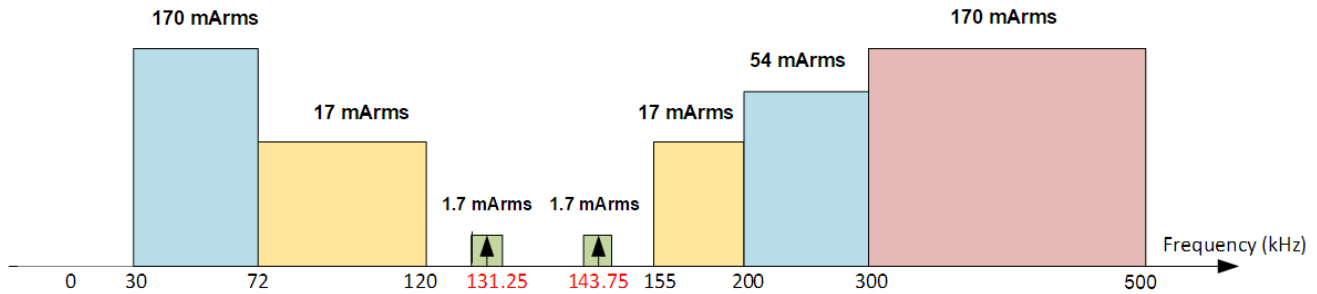

Figure 3.5: Out-of-band interferer rejection test levels

Test-2: OFF-state, the RSD must stay OFF in the presence of interferer. The interferer signal level shall be measured on the RL load resistor (see Figure 3.1). The test procedure is the following:

1. PS is set to $V_{mod} = 20 \text{ V}$, $R_L = 10 \text{ ohm}$, $P_r \geq (N_{inp} * V_{mod})^2 / R_L$, where N_{inp} is the number of inputs of the RSD
2. the SunSpec Keep-Alive signal on AWG Ch-1 is stopped
3. AWG Ch-2 is set to Continuous Wave (CW)
4. for each frequency in Table 3.3, AWG Ch-2 amplitude is set so that V_{acrl} equal the corresponding value. V_{acrl} is measured between the FSK bursts, as shown in Figure 3.6

The test PASSES if at each CW frequency the RSD stays in OFF-state

3.2.4.Receiver impedance tests

The reference for these tests is paragraph 5.3 of [1] and Footnote 9 of Table 6.

The goal of these tests is to check that the impedance of the receiver is within the limits defined in Table 6 of [1] both in active (ON) and in passive (OFF) mode.

3.2.4.1. Receiver impedance in OFF state at Fmark and Fspace

The OFF-state impedance shall be measured using the test setup of Figure 3.1. **N_{inp}** is the number of PV modules connected to the RSD (Figure 3.2). The test procedure is the following:

1. PS is set to $V_{mod} =$ the rated input voltage of each RSD input
2. $R_L = 100 \text{ ohm}$, $P_r \geq (N_{inp} * V_{mod})^2 / R_L$
where P_r is the rated power of R_L (in case a defective RSD turns on)
3. AWG Ch-1 amplitude is set to 0 Vp-p
4. AWG Ch-2 amplitude is set to 1 Vp-p
5. AWG Ch-2 generates $F_{mark} = 131.25 \text{ kHz}$ continuous sine wave → this must not turn ON the RSDs

6. using an oscilloscope or another DAQ equipment, the VacRSD and Vacrl amplitudes are measured. The receiver impedance is calculated as the following:

$$|Z_{off_mark}| = \text{VacRSD} / \text{Vacrl} * \text{RL}$$

7. AWG Ch-2 generates Fspace = 143.75 kHz continuous sine wave
8. the VacRSD and Vacrl amplitudes are measured

$$|Z_{off_space}| = \text{VacRSD} / \text{Vacrl} * \text{RL}$$

The test **PASSES** if, according to Table 6 of [1]

$$\underline{N_{inp} * 1 \text{ ohm} \leq |Z_{off_mark}| \leq N_{inp} * 8 \text{ ohm and}}$$

$$\underline{N_{inp} * 1 \text{ ohm} \leq |Z_{off_space}| \leq N_{inp} * 8 \text{ ohm}}$$

3.2.4.2. Receiver impedance in ON state at Fmark and Fspace

As in the case of the sensitivity test, two measurements shall be taken: Test-1 with voltages close to the rated maximum input voltage ($0.9 * V_{max}$) of the RSD applied to the inputs and Test-2 with a load current close to the rated maximum ($0.8 * I_{max}$) of the RSD. **Ninp** is the number of PV modules connected to the RSD (Figure 3.2).

The test procedure is the following:

Test-1 (HighV):

1. PS is set to $V_{mod} = 0.9 * V_{max}$, $I_{limit} = 1.2 * P_{max} / V_{mod}$
where $P_{max} = 600 \text{ W}$ or the rated power per RSD input if it is lower
2. $RL = N_{inp} * (V_{mod}/I_{test} - R_s)$, $Pr > I_{test}^2 * RL$
where N_{inp} is the number of inputs, $I_{test} = P_{max} / V_{mod}$ and Pr is the rated power of RL
3. AWG Ch-1 amplitude is set to 1 Vp-p, Ch-2 amplitude is set to 0 Vp-p
4. the SunSpec Keep-Alive signal is loaded in AWG Ch-1 → this must switch ON the RSDs
5. using an oscilloscope or another DAQ equipment, the VacRSD and Vacrl amplitudes are measured on a 'MARK' portion of the PLC signal, as shown in Figure 3.3. The receiver impedance is calculated as the following:

$$|Z_{on_mark}| = \text{VacRSD} / \text{Vacrl} * \text{RL}$$

6. the VacRSD and Vacrl amplitudes are measured on a 'SPACE' portion of the PLC signal

$$|Z_{on_space}| = \text{VacRSD} / \text{Vacrl} * \text{RL}$$

Test-2 (HighI):

1. PS is set to $V_{mod} = P_{max} / I_{test}$, $I_{limit} = I_{max}$
where I_{max} is the rated maximum current of the RSD, $I_{test} = 0.8 * I_{max}$
and $P_{max} = 600 \text{ W}$ or the rated power per RSD input if it is lower
2. $RL = N_{inp} * (V_{mod}/I_{test} - R_s)$, $Pr > I_{test}^2 * RL$

3. to 6. are the same as for Test-1

The test **PASSES** if, according to Table 6 of [1], in both tests

$$\underline{Ninp * 1 \text{ ohm} \leq |Zon_mark| \leq Ninp * 8 \text{ ohm and}}$$

$$\underline{Ninp * 1 \text{ ohm} \leq |Zon_space| \leq Ninp * 8 \text{ ohm}}$$

3.2.4.3. Receiver impedance in ON state in the 20 kHz - 200 kHz range

A combination of the RSD FSK signal and of a CW (Continuous Wave) signal is sent by the Wave Generator to keep the RSD ON and to have the frequency component at which the measurement is done.

The same way as for the Fmark and Fspace frequencies, two measurements shall be taken: Test-1 with voltages close to the rated maximum input voltage ($0.9 * V_{max}$) of the RSD applied to the inputs and Test-2 with a load current close to the rated maximum ($0.8 * I_{max}$) of the RSD. **Ninp** is the number of PV modules connected to the RSD (Figure 3.2). The test procedure is the following:

Test-1 (HighV):

1. PS is set to $V_{mod} = 0.9 * V_{max}$, $I_{limit} = 1.2 * P_{max} / V_{mod}$
where $P_{max} = 600 \text{ W}$ or the rated power per RSD input if it is lower
2. $RL = Ninp * (V_{mod}/I_{test} - R_s)$, $Pr > I_{test}^2 * RL$
where $Ninp$ is the number of inputs, $I_{test} = P_{max} / V_{mod}$ and Pr is the rated power of RL
3. AWG Ch-1 amplitude is set to $1 V_{p-p}$
4. the SunSpec Keep-Alive signal is loaded in AWG Ch-1 → this turns ON the RSDs
5. Ch-2 amplitude is set to $1 V_{p-p}$, Continuous Wave (CW)
6. Ch-2 CW frequency is set to 20 kHz and then increased by 10 kHz steps up to 200 kHz
7. using an oscilloscope or another DAQ equipment, the V_{acRSD} and V_{acrl} amplitudes shall be measured at each CW frequency, between the FSK bursts, as illustrated in Figure 3.6. The receiver impedance is calculated as the following:

$$|Zon_wb| = V_{acRSD} / V_{acrl} * RL \text{ - measured at each frequency}$$

Test-2 (HighI):

1. PS is set to $V_{mod} = P_{max} / I_{test}$, $I_{limit} = I_{max}$
where I_{max} is the rated maximum current of the RSD, $I_{test} = 0.8 * I_{max}$
and $P_{max} = 600 \text{ W}$ or the rated power per RSD input if it is lower
2. $RL = Ninp * (V_{mod}/I_{test} - R_s)$, $Pr > I_{test}^2 * RL$
3. to 7. are the same as for Test-1

The test **PASSES** if, according to Table 6 of [1], in both tests

$$|Z_{on\ wb}| \leq N_{inp} * 6\ \text{ohm}$$

$$20\ \text{kHz} \leq F \leq 100\ \text{kHz}$$

$$|Z_{on\ wb}| \leq N_{inp} * 8\ \text{ohm}$$

$$100\ \text{kHz} < F \leq 200\ \text{kHz}$$

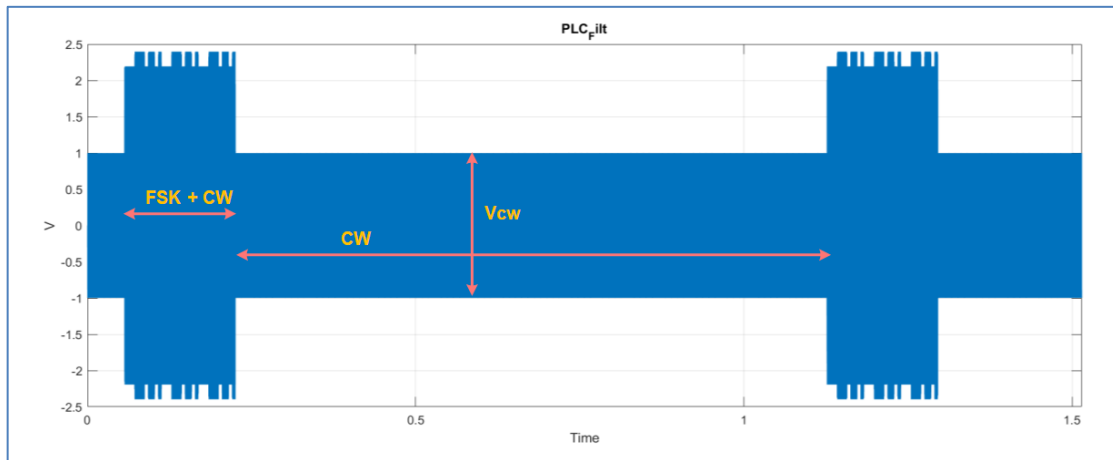

Figure 3.6: Powerline Communication with superimposed CW signal

3.2.5. Receiver shutdown output voltage test

This test is suitable for a unit consisting of a receiver and associated switches to control the power of a PV module. In a typical application this unit will be integrated into the junction box of a PV module. This unit has one or more input ports for a serial connection of PV cells and one switched output port, where the PV voltage is available in case the enabling signal is present.

The tests are conducted with no enabling signal present. The unit is in shutdown mode.

Aim of the test is to check the conformance of the unit to the requirements on I_{OFF} and I_{OFFHI} in Table 1 „Mode Transition Parameters“ in section 4.5 of the standard (*include suitable reference*).

The test shall be performed by supplying power to the device under test from either a PV module or a DC sources. Therefore two test setups are specified, but just the suitable one shall be performed.

3.2.6. Test setup 1 – powered by PV module

The unit is tested when mounted into the junction box of a PV module and connected to the cell strings of the module in a way specified by the manufacturer. The module shall be illuminated with enough light to conduct the tests. The irradiation shall be stable during the measurement. At the output port a variable load is connected.

3.2.7. Test setup 2 – powered with DC sources

The unit is powered by one or more DC power sources connected to its input ports. The setting of these power supplies shall be chosen in a way that the tests are not influenced by the lack of DC power and the maximum ratings of the units are not exceeded. The voltage of the DC power supply shall be stable during the measurement. At the output port a variable load is connected.

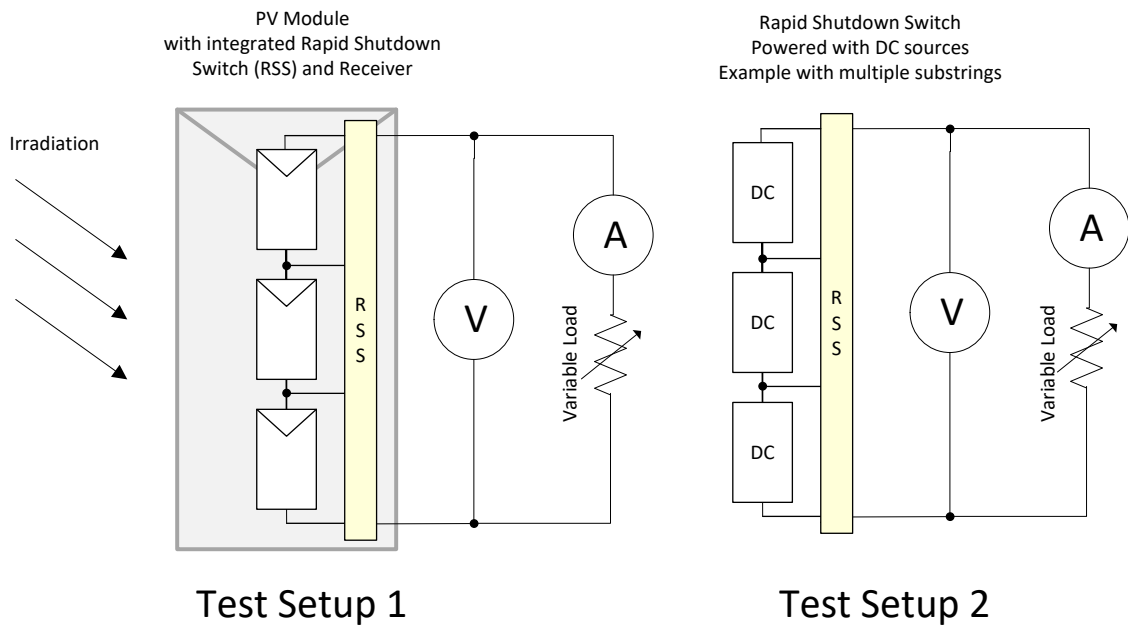

Figure 3.7: Test setup 1 and 2

3.2.8. Test procedure

The variable load is decreased until an output current of 10 mA is reached. At 10 mA the unit shall be operated for a minimum time of 1 Minute. During this procedure (ramp up and operation at 10 mA) the output voltage shall be measured. If the output voltage equals or exceeds 0.6 V with an output current from 0 mA to 10 mA the criteria for I_{OFF} has been met. Current and voltage shall be recorded for the measurement report.

If the unit includes the option „high power” for the shutdown mode the test shall be executed with an output current of up to 400 mA instead of up to 10 mA. If the continuous output voltage equals or exceeds 0.6 V with an output current of up to 400 mA the criteria for I_{OFFHI} has been met. Current and voltage shall be recorded for the measurement report.

3.2.9. Measurement equipment

Current and voltage shall be measured with a maximum error of 1% of the measured value.

4. Equipment interoperability test specification

4.1. Technical Interoperability definition

For telecommunication standards, **Technical Interoperability** is usually associated with hardware/software components, systems or platforms that enable machine-to-machine communication to take place. This document covers the **Technical Interoperability** of equipment embedding Rapid shutdown communication signal transmitters and receivers from two different manufacturers.

The Technical Interoperability of telecom equipment is generally performed during Plugfest events where transmitters and receivers from various manufacturers are connected together and specified interoperability tests (such as defined in part 2 of this document) are performed. At the end of the Plugfest events, tests are documented (as defined for each test of part 2) and a compatibility list of equipment could be created as proposed in table 4.1.

Transmitter	Receiver
Manufacturer A	Manufacturer B
Equipment reference A1	Equipment reference B1
	Equipment reference B2

	Equipment reference Bn
Equipment reference A2	Equipment reference B1
	Equipment reference B2

	Equipment reference Bn

Table 4.1: example of a list of interoperable equipment compatible with the SunSpec Rapid Shutdown specification

The following interoperability test does not cover all possible circumstances. Thus a passed interoperability test will not guarantee full interoperability or a proper function.

4.2. The prerequisite to interoperability test:

To perform the interoperability between a transmitter and a receiver, it is assumed that both devices have fulfilled the electrical conformance test for the Rapid Shutdown Communication Signal.

4.3. Symptoms of interoperability and non-interoperability:

Symptoms of interoperability:

From a Rapid Shutdown standpoint, two devices from two different manufacturers are considered as interoperable if based on an action from the transmitter, the proper behavior is shown by the receiver. The proper behavior corresponds to electrical and timing specifications as listed in [1].

In part 5 of this document, the different inter-operability tests, scenarios, and the expected actions of both the transmitter and receiver are defined.

A proper interoperability test of two different devices could be defined in the following manner:

- “Start process” test:
When the initiator is set in a permission to operate position, the transmitter sends a keep alive signal on the DC power line, the receiver demodulates the signal and connects the PV module on the string. This test is performed in conditions corresponding to short and long PV strings
- “Stop process” test:
When the initiator is switched to the Rapid Shutdown position, the transmitter stops sending the keep alive signal on the DC power line, the receiver detects that the signal is stopped and the output of the receiver to the PV string is set in standby mode according to the timing and electrical specification defined in [1]. This test is performed in conditions corresponding to short and long PV strings.
- “Repeatability and robustness of the interoperability” test:
The criticality of interoperability test is that the Rapid Shutdown function is targeted to be a safety feature of the PV installation, involving equipment from different manufacturers for the transmitter and the receiver.
The robustness (FMEA) and Safety Integrity Level of both the transmitter and receiver are supposed to be handled by both manufacturers during the design of their products. However, the repeatability of the interoperability of the emitter with the receiver shall be checked through a minimum number of start and stop processes. Arbitrarily, we propose to do 5 cycles of “start and stop” tests during the Plugtest considering that a regular verification (e.g. yearly) of the rapid shutdown functioning will have to be recommended, e.g. during the maintenance of the PV installation.
- “Multiple receivers’ interoperability” test:
In [1], it is defined that a single transmitter could be connected to up to 10 strings with up to 30 PV modules each. Interoperability test of 300 receivers with 1 transmitter does not look realistic in a plugtest. In part 5.4, we propose a test of 3 parallel receivers with a varying serial impedance simulating different length of strings.

Symptoms of non-interoperability:

There are two symptoms of non-interoperability:

- The receiver does not start or re-start properly after receiving a keep alive signal from the transmitter. This could be due to several reasons: the level/timing of signal received from the transmitter (long strings, multiple strings), the receiver demodulator performance, and the locked-in of the receiver due to some transient behavior.
- The receiver does not perform the rapid shutdown properly and according to the reference specification [1].

One of the goals of the plugtest is to ensure that instances of non-interoperability are not caused by poor or insufficient definition of the interoperability tests. For this purpose, and in order to find the root causes of non-interoperability, we propose to constantly monitor the DC line at the input of the receiver as defined in the overall interoperability test framework of part 4.4.

4.4. Overall interoperability test framework:

Figure 4.1 shows the principle schematic for testing the interoperability of a transmitter from manufacturer A with a receiver from manufacturer B:

- To reduce the complexity of the test and the test time, for the 3 first tests defined in part 1.3, use one single receiver associated with one transmitter.
- To evaluate the impact of the number of modules per string and the length of the string wires, a varying line impedance ZL shall be inserted on the string. Impact of parallel strings could also be simulated by inserting a parallel impedance at the output of the transmitter if needed.
One PV module with an added receiver shall be simulated by an inductance of 2.2 μ H to 2.9 μ H (including tolerances). This value simulates the impedance of one receiver together with the impedance of the wiring of one PV module.
The additional wiring per string shall be simulated with an inductance from 0 μ H up to the value of 220 μ H for the longest string.
- To evaluate the impact of parallel strings a parallel impedance at the output of the transmitter shall be inserted.
One pv-module with an added receiver shall be simulated by an impedance of 1.8 Ohm to 2.6 Ohm (including tolerances). This value simulates the impedance of one receiver, together with the impedance of the wiring of one PV module.
For the additional parallel strings, a total of 10 strings are connected in parallel with a wire length for each string corresponding to long wires.
- If the receiver is integrated inside a PV module, means shall be provided to give power to the receiver. Otherwise, for receivers embedded inside a retrofit box, the PV modules could be simulated by a DC power supply connected to the receiver.
- If the transmitter is embedded in an inverter, and if the inverter needs a minimum string voltage to operate properly, a serial controlled voltage source shall be inserted in the string to reach this minimum operating voltage. If the output impedance of this voltage source at the communication frequencies is not negligible, a suitable capacitor shall be added to the output of the controlled voltage source.
- If the transmitter needs the right standby voltage to start up, an additional controlled voltage source shall be inserted in series. At this point it is possible to use a low power supply or a current restricted supply, if this voltage source is bridged by a bypass diode. If the output impedance of this voltage source at the communication frequencies is not negligible, a suitable capacitor shall be added to the output of the controlled voltage source.

- String voltage and string current shall be monitored at the output of the receiver to validate the rapid shutdown operation and the start behavior on their 3 key parameters: string current, string voltage and timing.

Depending on manufacturers of transmitters and receivers, the installation manuals and product data sheets may use different numbers of panels in series and strings in parallel for worst case testing. In this case, the interoperability test framework shall be adapted to the limits defined by the manufacturers, stating in the interoperability table (table 4.1) the specific limits considered in the interoperability test.

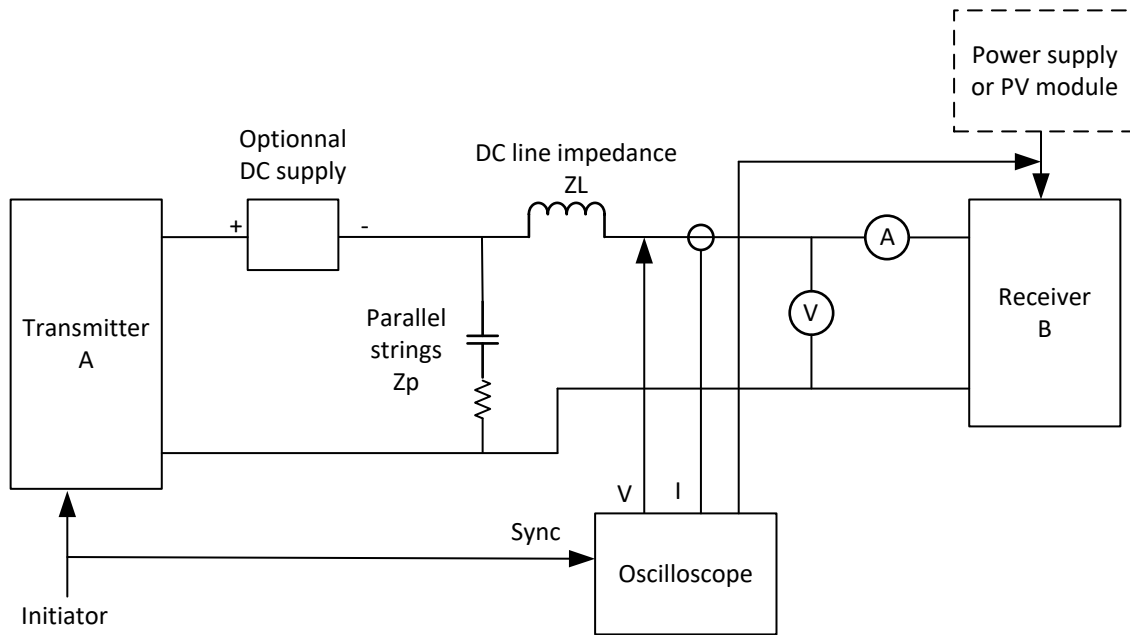

Figure 4.1: Principle of interoperability test framework

5. Interoperability test sequences

5.1. Start Process interoperability test: single receiver

The “start process” interoperability test shall be performed according the principle schematic shown in figure 4.1.

The test process is described in table 5.1 and the timing diagram is shown in figure 5.1.

Interoperability test description			
Identifier	"Start process" from a Rapid shutdown position		
Test objective	Verify that when the transmitter starts from a rapid shutdown position of the initiator, the transmitter sends the keep alive signal properly, the receiver properly demodulates the signal and activates the control of the PV module. This test shall be performed with a) a single long (ZL=284 to 304 μ H + DUT) and b) a single short string (ZL=11 to 14.5 μ H + DUT) and c) a single short string with a long string wiring (ZL=11 to 14.5 μ H + 220 μ H + DUT) and Zp corresponding to 9 parallel strings of 6 modules with an average short string wiring impedance (Zp=10 Ohm equal to 90 Ohm per string, each with max. 10% tolerance)		
Pre-test conditions	The initiator is in rapid shutdown position, the transmitter and the receiver are properly powered (the receiver is connected to a PV module with sun or is connected to a DC supply simulating a PV module). This test is done first with one single long PV string impedance. It shall be verified that the string voltage is Voff and the string current is Ioff at the starting point.		
Test sequence			Verdict
Step	Step	pass	fail
1	The initiator is switched to the "normal operation" position and, after an unspecified ¹ period of time, the transmitter starts sending the keep alive signal on the PV DC line.	X	X
2	After less than 20 seconds from the commencement of valid SunSpec KeepAlive signaling at the output of the transmitter, the receiver has completed the demodulation of the keep alive signal and connects the PV module on the DC string causing the DC voltage to rise above 30V.		
3	Switch back the initiator to rapid shutdown position and restart step 1 and 2 with long string impedance and then with parallel strings impedances.		

Table 5.1: Start Process interoperability test steps

¹ SunSpec does not specify this time period. Manufacturers should provide an upper limit for their equipment to assist testing laboratories in conducting this test. This information need not be publicly disclosed.

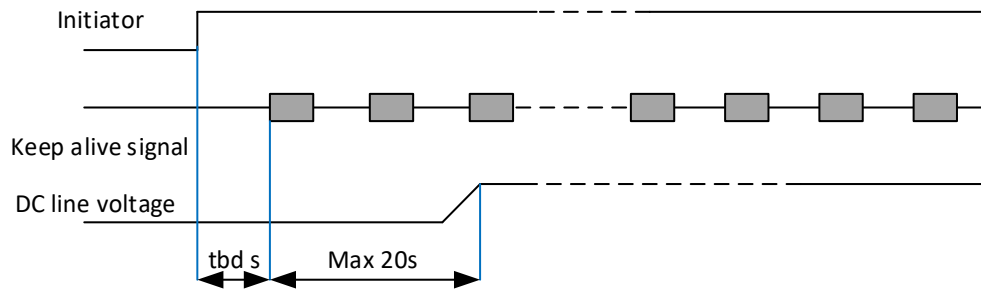

Figure 5.1: Start Process interoperability test timing

5.2. Stop Process interoperability test: single receiver

The “start process” interoperability test shall be performed according to the schematic shown in figure 4.1. The test process is described in table 5.2 and the timing diagram is shown in figure 5.2.

Interoperability test description				
Identifier	"Rapid shutdown process" from normal operation			
Test objective	Verify that when the transmitter is in normal operation and the initiator activates a rapid shutdown, then both transmitter and receiver are working properly according to the specification. This test shall be performed with a) a single long ($Z_L=284$ to $304\mu\text{H} + \text{DUT}$) and b) a single short string ($Z_L=11$ to $14.5\mu\text{H} + \text{DUT}$) and c) a single short string with a long string wiring ($Z_L=11$ to $14.5\mu\text{H} + 220\mu\text{H} + \text{DUT}$) and Z_p corresponding to 9 parallel strings of 6 modules with an average short string wiring impedance ($Z_p=10$ Ohm equal to 90 Ohm per string, each with max. 10% tolerance)			
Pre-test conditions	The initiator is "normal operation" position, the transmitter and the receiver are properly powered (the receiver is connected to a PV module with sun or is connected to a DC supply simulating a PV module), and the transmitter is sending the "keep alive signal. The string voltage and string current correspond to the standard operating conditions. This test is done first with a long PV string impedance.			
Test sequence			Verdict	
Step	Step		pass	fail
1	The initiator is switched to the "Rapid shutdown" position and after less than 4 seconds the transmitter stops sending the keep alive signal on the PV DC line.		X	X
2	After less than 17 seconds, the receiver has completed the demodulation of the keep alive signal, the string current is loff. After less than 30 seconds, the string voltage is Voff.			

3	Switch back the initiator to normal operation position and restart step 1 and 2 with long string impedance and then with parallel strings impedances.		
---	---	--	--

Table 5.2: Stop Process interoperability test steps

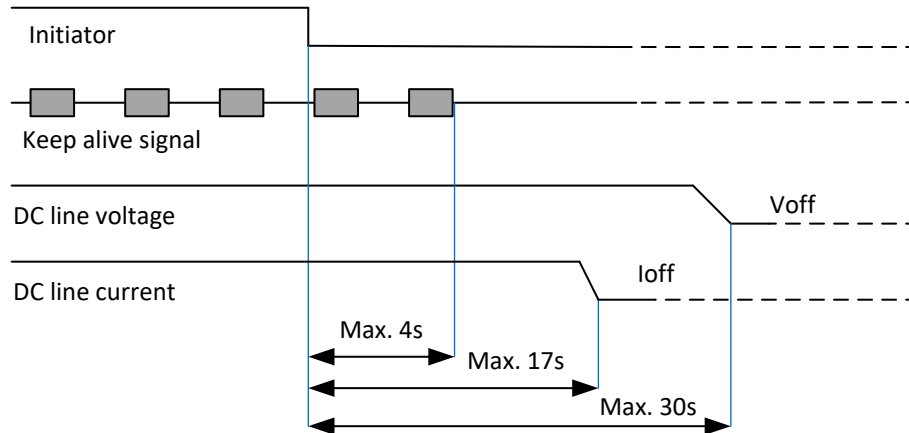

Figure 5.2: Stop Process interoperability test timing

5.3. Repeated Start and Stop interoperability test: single receiver

The repeated start and stop interoperability test shall be performed according to the principle schematic shown in figure 4.1. This test shall be performed with long string impedance to reduce the test time and due to the fact that the long line impedance corresponds to the sensitivity level.

The test process is described in table 5.3 and the timing diagram is shown in figure 5.3.

In this test, the initiator shall be cyclically toggled between rapid shutdown position and normal operation position with the following cycle time: 1 minute normal operation, 1 minute rapid shutdown position. For some specific needs, manufacturers of transmitters or receivers may specify more than 1 minute for the normal operation part of the cycle (longer re-start time) but for no longer than 5 minutes.

Interoperability test description			
Identifier	"repeated Start and Stop process" interoperability test		
Test objective	Verify that the rapid shutdown mode can be activated cyclically and properly through a minimum number of cycles (5). This test shall be performed with a long string (ZL=284 to 304uH)		
Pre-test conditions	The initiator is in "normal operation" position, the transmitter and the receiver are properly powered (the receiver is connected to a PV module with sun or is connected to a DC supply simulating a PV module), and the transmitter is sending the "keep alive signal". The string voltage and string current correspond to the standard operating conditions. This test shall be performed with a long PV string impedance (ZL=284 to 304uH). The initiator shall be cyclically toggled between rapid shutdown position and normal operation position with the following cycle time: 1minute normal operation, 1 minute rapid shutdown position.		
Test sequence			Verdict
Step	Step	pass	fail
1	The initiator is switched to the "Rapid shutdown" position and after less than 4 seconds the transmitter stops sending the keep alive signal on the PV DC line.	X	X
2	After less than 17 seconds, the receiver has completed the demodulation of the keep alive signal, the string current is loff. After less than 30 seconds, the string voltage is Voff.		
3	1 minute after rapid shutdown activation, the initiator is switched back to normal operation. Both the transmitter and the receiver switch back to normal operation (sending and receiving the keep alive signal)		
4	Step 1 to 3 shall be repeated 5 times		

Table 5.3: Repeated Start and Stop process" interoperability test steps

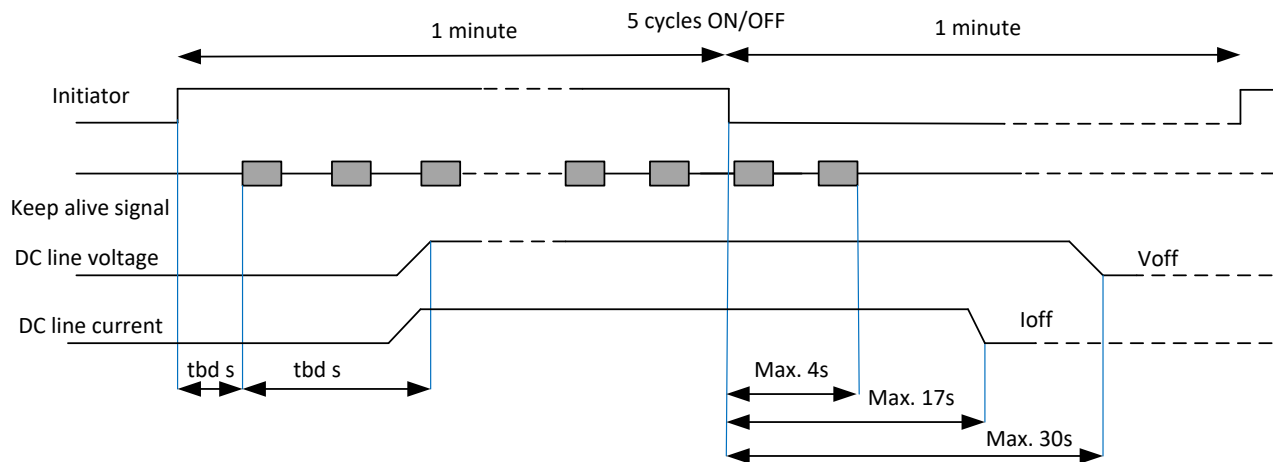

Figure 5.3: Repeated Start and Stop process interoperability test timing

5.4. Multiple receiver interoperability test:

The principle schematic for the interoperability test with multiple receivers is shown in figure 5.4. The string voltage and combined string current are measured at the input of the transmitter (after combination of the strings). For this test, we consider 6 modules per string and an impedance of wires varying between 0uH and 220uH so the line impedance associated to each receiver is: ZL1= short PV string (11 to 14.5μH), ZL2 = medium PV string (140uH) and ZL3 = long PV string (304,1μH). We also consider that 7 other strings are connected in parallel thus presenting an impedance of approximately Zp=16 Ohms. A multiple start and stop interoperability test similar to part 5.3 shall be performed. The table for test steps is similar to table 5.3 (but with ZL1= 11 to 14.5μH, ZL2=140uH, ZL3=304μH, Zp=16 Ohms) and the timing diagram is similar to figure 5.3 (but with “combined loff” instead of loff).

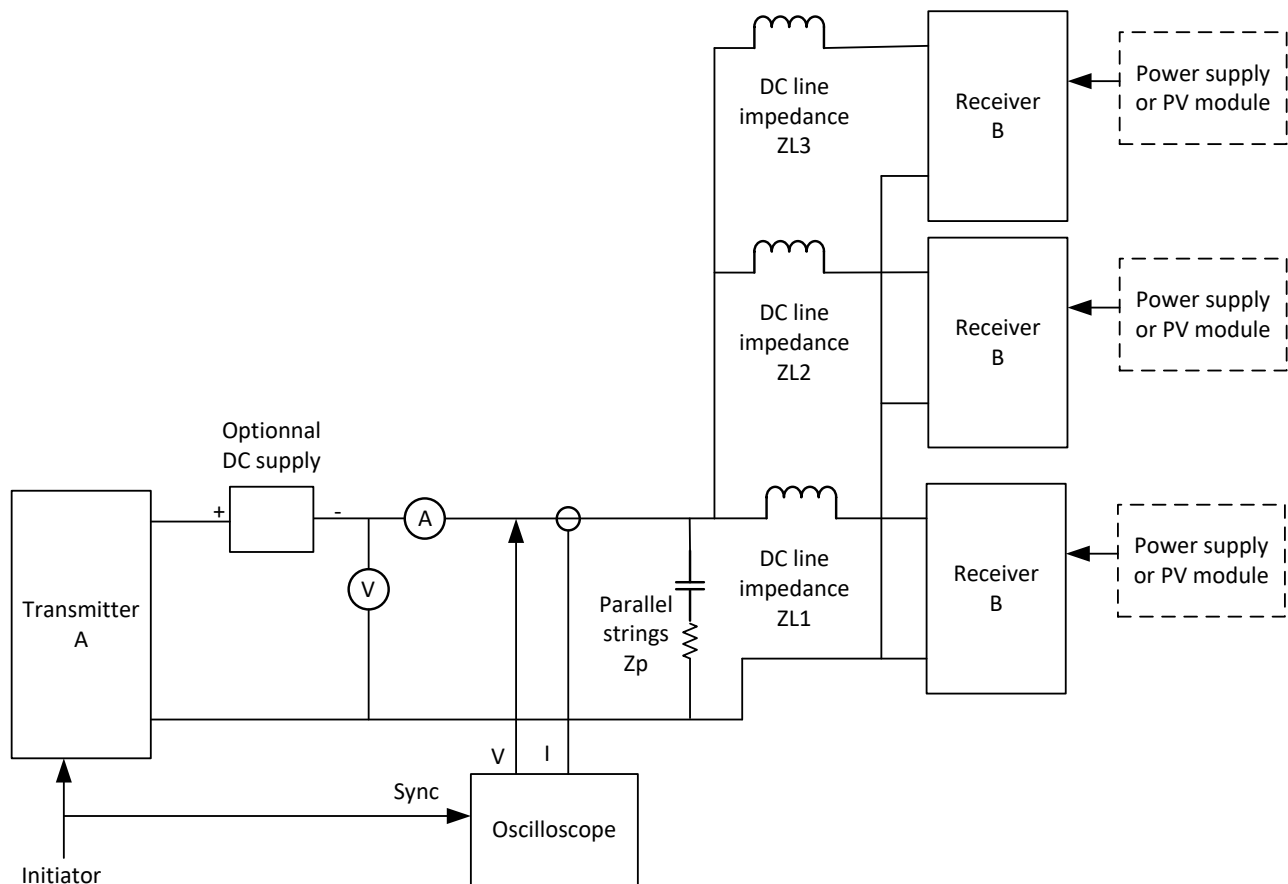

Figure 5.4: Multiple Receiver interoperability test diagram

APPENDIX A: Signal Timing and Waveform Accuracy

Informative: MATLAB CODE FOR SIGNAL TIMING AND WAVEFORM ACCURACY ASSESSMENT

The following MATLAB® script is an illustrative example of one possible approach to implementing the normative signal processing steps used for assessing SunSpec RSD keep-alive waveform accuracy and timing. Use of this code, or parts thereof, does not imply a correct implementation of any part of the official SunSpec test procedure.

```
%% read signal from file

load 'tx_capture.mat'% loads a vector named "signal"

Fs=2e6;      % sample rate, must match input tx_capture sample rate.

Tb=5.12e-3; % bit duration

bits_per_codeword=11;

codewords_per_period=19;

samples_per_period=round(codewords_per_period*bits_per_codeword*Tb*Fs);

%% compute bit waveform

N=round(Fs/6250); %filter length

assert(N*6250==Fs,'Sample rate not a multiple of the tone spacing');

bitwave=abs(filter(2*exp(1i*2*pi*21*(0:1/N:1-1/N))/N,1,signal)) - ...
          abs(filter(2*exp(1i*2*pi*23*(0:1/N:1-1/N))/N,1,signal));

%% define ideal reference for correlation searches

barker=[-1 -1 -1  1  1  1 -1  1  1 -1  1];

ref=kron(repmat(barker,1,3),ones(1,round(Fs*Tb)));

ref=ref/norm(ref); % normalize

%% find correlation peaks and their timing

Nexpected=floor(length(bitwave)/samples_per_period);

% truncate to integer number of duty-cycle periods

bitwave=bitwave(1:samples_per_period*Nexpected)';

bitwave=sqrt(Nexpected)*bitwave/norm(bitwave); %normalize

ref=[ref, zeros(1,length(bitwave)-length(ref))]; % zero-pad

% circular cross-correlation using FFT method

xcorr1=ifft((fft(bitwave)).*conj(fft(ref)));

[pks,locs]=findpeaks(abs(xcorr1),'MinPeakHeight',0.9,...
                    'MinPeakWidth',0,'MinPeakDistance',0);
```

```
[locs,i]=sort(locs);
pks=pks(i);
num_peaks=length(pks);
assert(num_peaks==Nexpected,'number of peaks found was not correct');
%% print a formatted table of results
actual_times=(locs-locs(1))/Fs;
ideal_times=(0:num_peaks-1)*codewords_per_period*bits_per_codeword*Tb;
ppm=1E6*(actual_times - ideal_times)./(ideal_times+eps);
T=[ideal_times',actual_times',pks',ppm'];
fprintf(1,'%s\t%s\t%s\t%s\n','ideal_time','actual_time','corr_coeff','ppm_drift');
fprintf(1,'%10.8f\t%10.8f\t%5.4f\t\t%4.1f\n',T');
```

APPENDIX B: Simulating Additional Receiver or Parallel Strings

Informative: Simulating additional receivers or parallel strings for the interoperability test

Simulating additional receiver in one string

In Table 6 of [1], the impedance of one receiver is specified to 0.7 to 1.5 Ohms. The attached wiring of a typical PV-Module is in the range of two times 0.9 m. In a best practice PV system the go and return line will be drilled to achieve a low inductance. A pair of 0.9m drilled PV wiring equates to approximately 1.3 μH additional inductance. To simulate one PV module with an added receiver simplified by an inductance, the impedance of the receiver has to be mapped to a corresponding inductance value: 0.7 Ohm @ 131.3 kHz = 0.9 μH ; 1.5Ohm @ 143.8kHz = 1.6 μH . Adding both values - wiring and receiver impedance - results in **2.2 μH to 2.9 μH** per simulated PV module including its attached module wiring.

Example: If one string composed of 6 modules in sum is intended to be emulated by one DUT together with an inductance in series, the value of the inductance shall be in the range of $5 \times (2.2\mu\text{H} \text{ to } 2.9\mu\text{H}) = 11 \text{ to } 14.5 \mu\text{H}$. To simulate the addition of PV DC-Power or a standby signal, a power supply has to also be added in series.

Simulating additional wiring in one string

To simulate the additional wiring from the PV array to the inverter, an additional inductance has to be added in series or the value of an existing inductance has to be increased. This specification covers up to **220 μH** of extra wiring in addition to the PV module attached wiring.

Example: If one string composed of 30 modules in sum with additional very long wiring to the inverter is intended to be emulated by one DUT together with an inductance in series, the value of the inductance shall be in the range of $29 \times (2.2\mu\text{H} \text{ to } 2.9\mu\text{H}) + 220\mu\text{H} = 283,8 \text{ to } 304,1 \mu\text{H}$. To simulate the addition of DC-Power or Standby Voltage a power supply has to be added in series too.

Simulating additional parallel strings

To simulate an entire parallel string without any DUT in series of this parallel string, an RC series circuit shall be used. The appropriate values are: 1.3 μH @ 131.3 kHz = 1.1 Ohm for the PV module attached wiring plus the receiver impedance of 0.7 to 1.5 Ohm \rightarrow **1.8 Ohm to 2.6 Ohm** per simulated PV module including its attached module wiring. To simulate the additional wiring from the PV array to the inverter, an additional resistance of up to **200 Ohm** shall be used ($\sim 220\mu\text{H}$ @ 143.8 kHz). The used capacitor shall be $\geq 1\mu\text{F}$ per simulated string.

Example: If one string composed of 30 modules in sum with additional very long wiring to the inverter is intended to be emulated without any DUT to this, a resistance in the range of $30 \times 1.8 \text{ Ohm to } 2.6 \text{ Ohm} + 200\text{Ohm} = 254 \text{ to } 278 \text{ Ohm}$ together with a capacitor of $\geq 1\mu\text{F}$ in series shall be added in parallel to the existing test setup.